

CHAPTER 8

COMPASSES

INTRODUCTION

800. Changes in Compass Technologies

This chapter discusses the major types of compasses available to the navigator, their operating principles, their capabilities, and limitations of their use. As with other aspects of navigation, technology is rapidly revolutionizing the field of compasses.

For much of maritime history the sole heading reference for navigators has been the magnetic compass. However, a great deal of effort and expense has gone into understanding the magnetic compass scientifically to make it as accurate as possible through research and development of elaborate compensation techniques.

Over time, technological advances like the development of more sophisticated means for obtaining accurate compass readings, such as the electro-mechanical gyrocompass, diminished traditional reliance upon the magnetic compass, relegating it to backup status in many large vessels. Later came the development of inertial navigation systems based on gyroscopic principles, but perturbations like the interruption of electrical power to the gyrocompass or inertial navigator, mechanical failure, and equipment deterioration have reminded navigators of the important reliability of the magnetic compass.

New technologies are both refining and replacing the magnetic compass as the primary heading reference and navigational tool. Although using a magnetic compass for backup is certainly advisable, today's navigator can safely rely on modern equipment, avoiding much of the effort and expense associated with the binnacle-mounted magnetic compass, such as the need for compensation, adjustment, and maintenance.

Similarly, even relatively new advances like the electro-mechanical gyrocompasses are being supplanted by far lighter, cheaper, and more dependable ring laser gyrocompasses. These devices do not operate on the principle of the gyroscope (which is based on Newton's laws of motion), but instead rely on the principles of electromagnetic energy and wave theory.

Magnetic flux gate compasses, while relying on the Earth's magnetic field for reference, have no moving parts and can compensate themselves, adjusting for both deviation and variation to provide true heading, thus completely eliminating the process of compass correction.

To the extent that one depends on the magnetic compass for navigation, it should be checked regularly and adjusted when observed errors exceed certain minimal limits, usually a few degrees for most vessels. Compensation of a magnetic compass aboard vessels where navigators are expected to rely on it offshore or during long voyages is best left to professionals. However, this chapter will present enough material for the competent navigator to do an adequate job.

Whatever type of compass being used for navigation, it is advisable to check it periodically against an error free reference to determine its error. This may be done when steering along any range during harbor and approach navigation, or by aligning any two charted objects to find the difference between their observed and charted bearings. When navigating offshore, the use of azimuths and amplitudes of celestial bodies is also an effective method; a subject covered in Chapter 15 - Azimuths and Amplitudes.

MAGNETIC COMPASSES

801. The Magnetic Compass and Magnetism

The principle of the present day magnetic compass is no different from that of the compasses used by ancient mariners. The magnetic compass consists of a magnetized needle, or an array of needles, allowed to rotate freely in the horizontal plane. The superiority of present-day magnetic compasses over ancient ones results from a better knowledge of the laws of magnetism and how it governs the behavior of the compass and from greater precision in

design and construction.

Any magnetized piece of metal will have regions of concentrated magnetism called **poles**. Any such magnet will have at least two poles of opposite polarity. Magnetic force (flux) lines connect one pole of such a magnet with the other pole. The number of such lines per unit area represents the intensity of the **magnetic field** in that area.

When two magnets are placed close to each other, the like poles will repel each other and the unlike poles will attract each other.

Magnetism can be either **permanent** or **induced**. A bar having permanent magnetism will retain its magnetism when it is removed from a magnetizing field. A bar having induced magnetism will lose its magnetism when removed from the magnetizing field. Whether or not a bar will retain its magnetism on removal from the magnetizing field will depend on the strength of that field, the degree of hardness of the iron (retentivity), and upon the amount of physical stress applied to the bar while in the magnetizing field. The harder the iron, the more permanent will be the magnetism acquired.

802. Terrestrial Magnetism

Consider the Earth as a huge magnet surrounded by lines of magnetic flux connecting its two **magnetic poles**. These magnetic poles are near, but not coincidental with, the Earth's geographic poles. Since the north seeking end of a compass needle is conventionally called the **north pole**, or **positive pole**, it must therefore be attracted to a **south pole**, or **negative pole**.

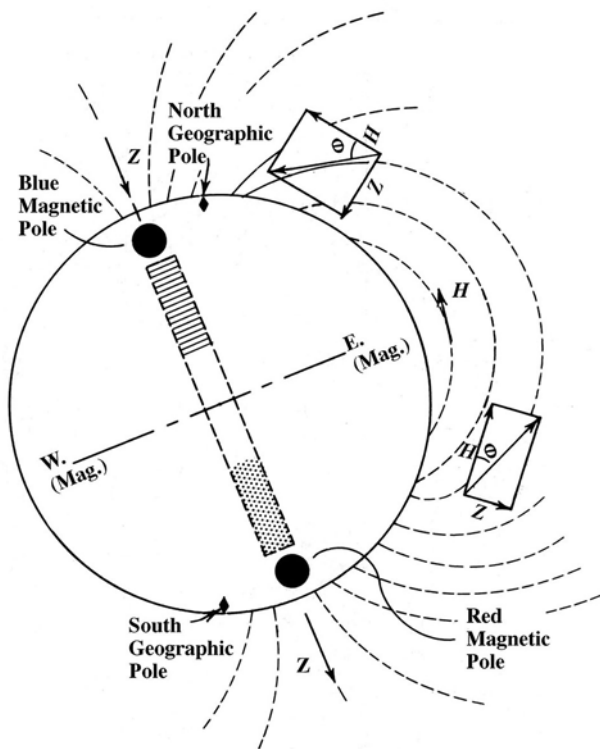

Figure 802a. Terrestrial magnetism.

Figure 802a illustrates the Earth and its surrounding magnetic field. The flux lines enter the surface of the Earth at different angles to the horizontal at different magnetic latitudes. This angle is called the **angle of magnetic dip**, θ , and increases from 0° at the magnetic equator to 90° at the magnetic poles. The total magnetic field is generally considered as having two components: H, the horizontal component; and Z, the vertical component. These components change as the angle θ changes,

such that H is at its maximum at the magnetic equator and decreases in the direction of either pole, while Z is zero at the magnetic equator and increases in the direction of either pole.

Since the magnetic poles of the Earth do not coincide with the geographic poles, a compass needle in line with the Earth's magnetic field will not indicate true north, but magnetic north. The angular difference between the true meridian (great circle connecting the geographic poles) and the magnetic meridian (direction of the lines of magnetic flux) is called **variation**. This variation has different values at different locations on the Earth. These values of magnetic variation may be found on pilot charts and on the compass rose of navigational charts. Magnetic variations is sometimes called magnetic declination.

The poles are not geographically static. They are known to migrate slowly, so that variation for most areas undergoes a small annual change, the amount of which is also noted on charts.

More information on geomagnetism is available at the U.S. Geological Survey (USGS) website: <http://geomag.usgs.gov/>.



Figure 802b. USGS Geomagnetism Program.

803. The World Magnetic Model

The World Magnetic Model is a joint product of the United States' National Geospatial-Intelligence Agency (NGA) and the United Kingdom's Defence Geographic Centre (DGC). The WMM was developed jointly by the National Geophysical Data Center (NGDC, Boulder CO, USA) (now the National Centers for Environmental Information (NCEI)) and the British Geological Survey (BGS, Edinburgh, Scotland).



Figure 803a. World Magnetic Model
<https://www.ngdc.noaa.gov/geomag/WMM/DoDWMM.shtml>

The World Magnetic Model is the standard model used by the U.S. Department of Defense, the U.K. Ministry of Defence, the North Atlantic Treaty Organization (NATO) and the International Hydrographic Organization (IHO), for navigation, attitude

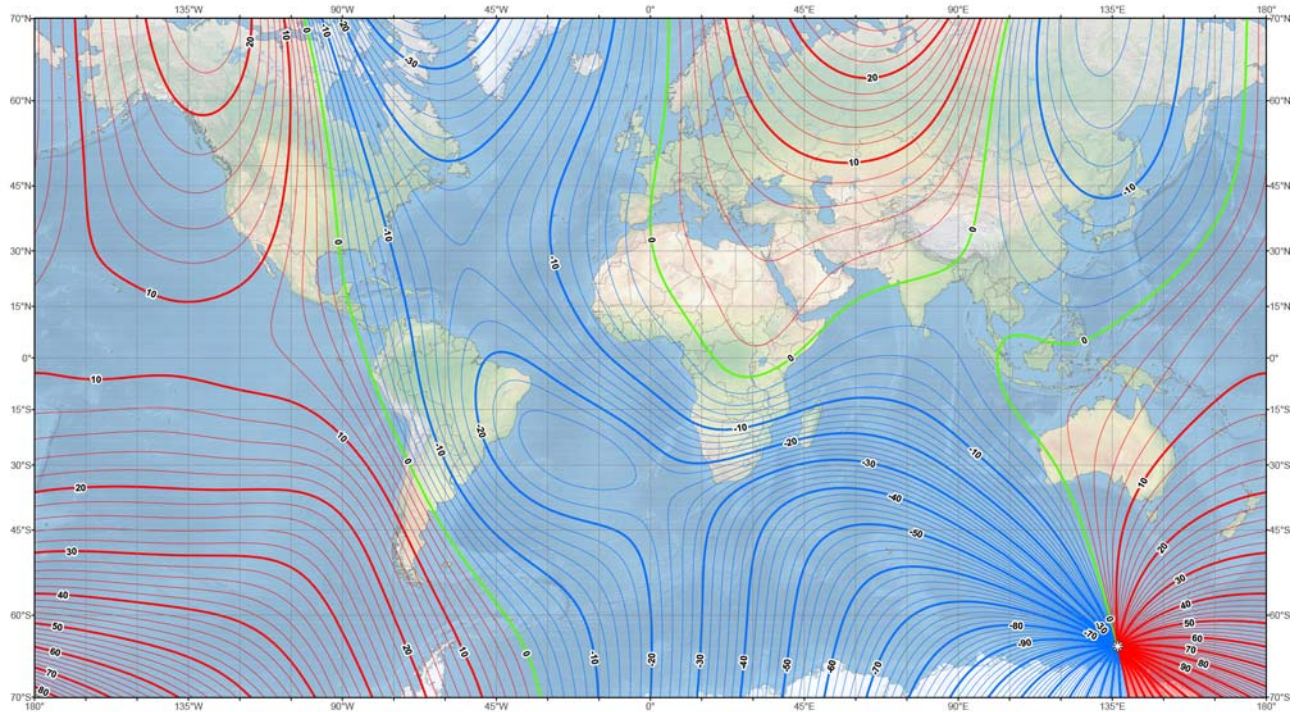

Figure 803b. Magnetic variation for the world (2015 Epoch).

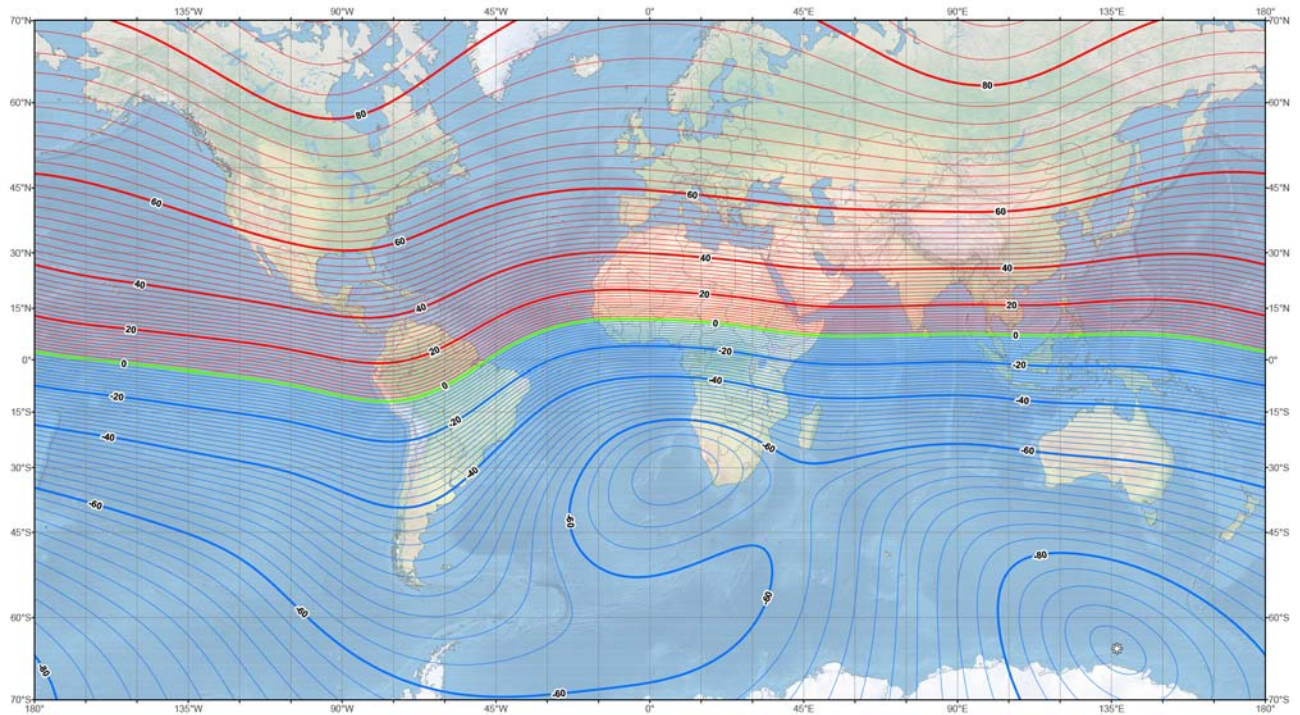

Figure 803c. Magnetic dip for the world (2015 Epoch).

and heading referencing systems using the geomagnetic field. It is also used widely in civilian navigation and heading systems. The model, associated software, and documentation are distributed by NCEI on behalf of NGA. The model is produced at 5-year

intervals, with the current model expiring on December 31, 2019. Figure 803b and Figure 803c show magnetic dip and variation (2015 epoch) for the world. Red contours are positive or east, blue contours are negative or west and green is agonic or zero.

804. Ship's Magnetism

A ship under construction or repair will acquire permanent magnetism due to hammering and vibration while sitting stationary in the Earth's magnetic field. After launching, the ship will lose some of this original magnetism as a result of vibration and pounding in varying magnetic fields, and will eventually reach a more or less stable magnetic condition. The magnetism which remains is the **permanent magnetism** of the ship.

In addition to its permanent magnetism, a ship acquires **induced magnetism** when placed in the Earth's magnetic field. The magnetism induced in any given piece of soft iron is a function of the field intensity, the alignment of the soft iron in that field, and the physical properties and dimensions of the iron. This induced magnetism may add to, or subtract from, the permanent magnetism already present in the ship, depending on how the ship is aligned in the magnetic field. The softer the iron, the more readily it will be magnetized by the Earth's magnetic field, and the more readily it will give up its magnetism when removed from that field.

The magnetism in the various structures of a ship, which tends to change as a result of cruising, vibration, or aging, but which does not alter immediately so as to be properly termed induced magnetism, is called **subpermanent magnetism**. This magnetism, at any instant, is part of the ship's permanent magnetism, and consequently must be corrected by permanent magnet correctors. It is the principal cause of deviation changes on a magnetic compass. Subsequent reference to permanent magnetism will refer to the apparent permanent magnetism which includes the existing permanent and subpermanent magnetism.

A ship, then, has a combination of permanent, subpermanent, and induced magnetism. Therefore, the ship's apparent permanent magnetic condition is subject to change as a result of deperming, shocks, welding, and vibration. The ship's induced magnetism will vary with the Earth's magnetic field strength and with the alignment of the ship in that field.

805. Magnetic Adjustment

A narrow rod of soft iron, placed parallel to the Earth's horizontal magnetic field, H , will have a north pole induced in the end toward the north geographic pole and a south pole induced in the end toward the south geographic pole. This same rod in a horizontal plane, but at right angles to the horizontal Earth's field, would have no magnetism induced in it, because its alignment in the magnetic field precludes linear magnetization, if the rod is of negligible cross section. Should the rod be aligned in some horizontal direction between those headings which create maximum and zero induction, it would be induced by an amount which is a function of the angle of alignment. However, if a similar rod is placed in a vertical position in northern latitudes so as to be aligned with the vertical Earth's field Z , it will have a south pole induced at the upper end

and a north pole induced at the lower end. These polarities of vertical induced magnetization will be reversed in southern latitudes.

The amount of horizontal or vertical induction in such rods, or in ships whose construction is equivalent to combinations of such rods, will vary with the intensity of H and Z , heading, and heel of the ship.

The magnetic compass must be corrected for the vessel's permanent and induced magnetism so that its operation approximates that of a completely nonmagnetic vessel. Ship's magnetic conditions create magnetic compass deviations and sectors of sluggishness and unsteadiness. **Deviation** is defined as deflection right or left of the magnetic meridian caused by magnetic properties of the vessel. Adjusting the compass consists of arranging magnetic and soft iron **correctors** near the compass so that their effects are equal and opposite to the effects of the magnetic material in the ship.

The total permanent magnetic field effect at the compass may be broken into three components, mutually 90° to each other (see Figure 805a).

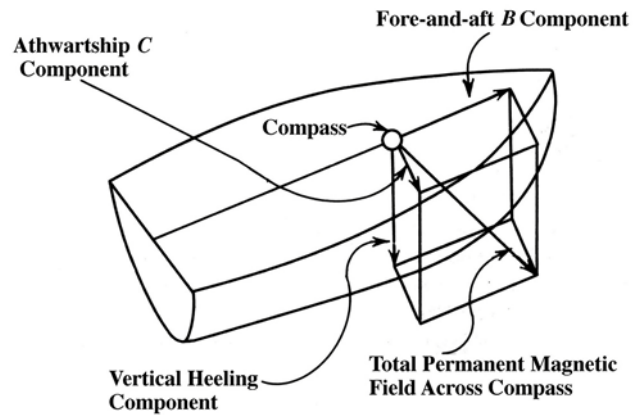

Figure 805a. Components of permanent magnetic field.

The vertical permanent component tilts the compass card, and, when the ship rolls or pitches, causes oscillating deflections of the card. Oscillation effects which accompany roll are maximum on north and south compass headings, and those which accompany pitch are maximum on east and west compass headings.

The horizontal B and C components of permanent magnetism cause varying deviations of the compass as the ship swings in heading on an even keel. Plotting these deviations against compass heading yields the sine and cosine curves shown in Figure 805b. These deviation curves are called semicircular curves because they reverse direction by 180° .

A vector analysis is helpful in determining deviations or the strength of deviating fields. For example, a ship as shown in Figure 805c on an east magnetic heading will subject its compass to a combination of magnetic effects; namely, the Earth's horizontal field H , and the deviating field B , at right

angles to the field H . The compass needle will align itself in the resultant field which is represented by the vector sum of H and B , as shown. A similar analysis will reveal that the resulting directive force on the compass would be maximum on a north heading and minimum on a south heading because the deviations for both conditions are zero. The magnitude of the deviation caused by the permanent B magnetic field will vary with different values of H ; hence, deviations resulting from permanent magnetic fields will vary with the magnetic latitude of the ship.

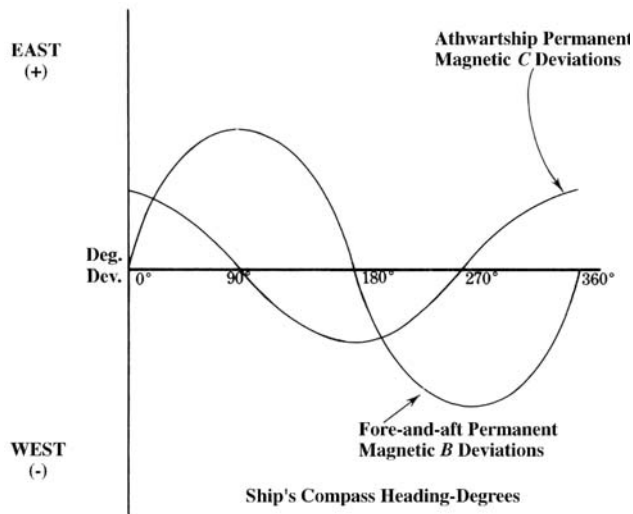

Figure 805b. Permanent magnetic deviation effects.

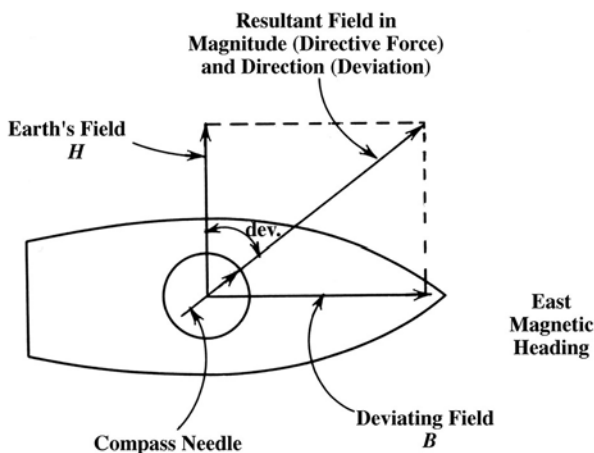

Figure 805c. General force diagram.

806. Effects of Induced Magnetism

Induced magnetism varies with the strength of the surrounding field, the mass of metal, and the alignment of the metal in the field. Since the intensity of the Earth's magnetic field varies over the Earth's surface, the induced magnetism in a ship will vary with latitude, heading, and heeling angle.

With the ship on an even keel, the resultant vertical induced magnetism, if not directed through the compass itself, will create deviations which plot as a semicircular deviation curve. This is true because the vertical induction changes magnitude and polarity only with magnetic latitude and heel, and not with heading of the ship. Therefore, as long as the ship is in the same magnetic latitude, its vertical induced pole swinging about the compass will produce the same effect on the compass as a permanent pole swinging about the compass.

The Earth's field induction in certain other unsymmetrical arrangements of horizontal soft iron create a constant A deviation curve. In addition to this magnetic A error, there are constant A deviations resulting from: (1) physical misalignments of the compass, pelorus, or gyro; (2) errors in calculating the Sun's azimuth, observing time, or taking bearings.

The nature, magnitude, and polarity of these induced effects are dependent upon the disposition of metal, the symmetry or asymmetry of the ship, the location of the binnacle, the strength of the Earth's magnetic field, and the angle of dip.

Certain heeling errors, in addition to those resulting from permanent magnetism, are created by the presence of both horizontal and vertical soft iron which experience changing induction as the ship rolls in the Earth's magnetic field. This part of the heeling error will change in magnitude proportional to changes of magnetic latitude of the ship. Oscillation effects associated with rolling are maximum on north and south headings, just as with the permanent magnetic heeling errors.

807. Adjustments and Correctors

Since some magnetic effects are functions of the vessel's magnetic latitude and others are not, each individual effect should be corrected independently. Furthermore, to make the corrections, we use (1) permanent magnet correctors to compensate for permanent magnetic fields at the compass, and (2) soft iron correctors to compensate for induced magnetism. The compass binnacle provides support for both the compass and its correctors. Typical large ship binnacles hold the following correctors:

1. Vertical permanent **heeling magnet** in the central vertical tube directly beneath the compass.
2. Fore-and-aft **B permanent magnets** in their trays.
3. Athwartship **C permanent magnets** in their trays.
4. Vertical soft iron **Flinders bar** in its external tube.
5. Soft iron **quadrantal spheres**.

The heeling magnet is the only corrector which corrects for both permanent and induced effects. Therefore, it may need to be adjusted for changes in latitude if a vessel permanently changes its normal operating area. However, any movement of the heeling magnet will require readjustment of other correctors.

Fairly sophisticated magnetic compasses used on smaller commercial craft, larger yachts, and fishing vessels,

may not have soft iron correctors or B and C permanent magnets. These compasses are adjusted by rotating magnets located inside the base of the unit, adjustable by small screws on the outside. A non-magnetic screwdriver is necessary to adjust these compasses. Occasionally one may find a permanent magnet corrector mounted near the compass, placed during the initial installation so as to remove a large, constant deviation before final adjustments are made.

Normally, this remains in place for the life of the vessel.

Figure 807 summarizes all the various magnetic conditions in a ship, the types of deviation curves they create, the correctors for each effect, and headings on which each corrector is adjusted. When adjusting the compass, always apply the correctors symmetrically and as far away from the compass as possible. This preserves the uniformity of magnetic fields about the compass needle.

Coefficient	Type deviation curve	Compass headings of maximum deviation	Causes of such errors	Correctors for such errors	Magnetic or compass headings on which to apply correctors
A	Constant.	Same on all.	Human-error in calculations Physical-compass, gyro, pelorus alignment Magnetic-unsymmetrical arrangements of horiz. soft iron.	Check methods and calculations Check alignments Rare arrangement of soft iron rods.	Any.
B	Semicircular $\sin \phi$.	090° 270°	Fore-and-aft component of permanent magnetic field Induced magnetism in unsymmetrical vertical iron forward or aft of compass.	Fore-and-aft B magnets Flinders bar (forward or aft)	090° or 270°.
C	Semicircular $\cos \phi$.	000° 180°	Athwartship component of permanent magnetic field Induced magnetism in unsymmetrical vertical iron port or starboard of compass.	Athwartship C magnets Flinders bar (port or starboard)	000° or 180°.
D	Quadrantal $\sin 2\phi$.	045° 135° 225° 315°	Induced magnetism in all symmetrical arrangements of horizontal soft iron.	Spheres on appropriate axis. (athwartship for +D) (fore and aft for -D) <i>See sketch a</i>	045°, 135°, 225°, or 315°.
E	Quadrantal $\cos 2\phi$.	000° 090° 180° 270°	Induced magnetism in all unsymmetrical arrangements of horizontal soft iron.	Spheres on appropriate axis. (port fwd.-stb'd for +E) (stb'd fwd.-port aft for -E) <i>See sketch b</i>	000°, 090°, 180°, or 270°.
Heeling	Oscillations with roll or pitch. Deviations with constant list.	000° 180° 090° 270°	Change in the horizontal component of the induced or permanent magnetic fields at the compass due to rolling or pitching of the ship.	Heeling magnet (must be readjusted for latitude changes).	090° or 270° with dip needle. 000° or 180° while rolling.
		roll pitch			

Deviation = $A + B \sin \phi + C \cos \phi + D \sin 2\phi + E \cos 2\phi$ (ϕ = compass heading)

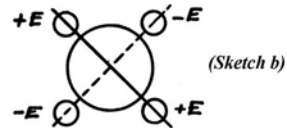
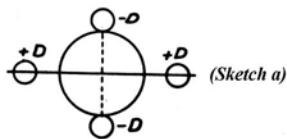

Figure 807. Summary of compass errors and adjustments.

Occasionally, the permanent magnetic effects at the location of the compass are so large that they overcome the Earth's directive force, H. This condition will not only create sluggish and unsteady sectors, but may even freeze the compass to one reading or to one quadrant, regardless of the heading of the ship. Should the compass become so frozen, the polarity of the magnetism which must be attracting the compass needles is indicated; hence, correction may be effected simply by the application of permanent magnet correctors to neutralize this magnetism. Whenever such adjustments are made, the ship should be steered on a heading such that the unfreezing of the compass needles will be immediately evident. For example, a ship whose compass is frozen to a north reading would require fore-and-aft B corrector magnets with the positive ends forward in order to neutralize the existing negative pole which attracted the com-

pass. If made on an east heading, such an adjustment would be evident when the compass card was freed to indicate an east heading.

808. Reasons for Correcting Compass

There are several reasons for correcting the errors of a magnetic compass, even if it is not the primary directional reference:

1. It is easier to use a magnetic compass if the deviations are small.
2. Even known and fully compensated deviation introduces error because the compass operates sluggishly and unsteadily when deviation is present.

3. Even though the deviations are compensated for, they will be subject to appreciable change as a function of heel and magnetic latitude.

Theoretically, it doesn't matter what the compass error is as long as it is known. But a properly adjusted magnetic compass is more accurate in all sea conditions, easier to steer by, and less subject to transient deviations which could result in deviations from the ship's chosen course.

Therefore, if a magnetic compass is installed and meant to be relied upon, it behooves the navigator to attend carefully to its adjustment. Doing so is known as "swinging ship."

809. Adjustment Check-off List

While a professional compass adjuster will be able to obtain the smallest possible error curve in the shortest time, many ship's navigators adjust the compass themselves with satisfactory results. Whether or not a "perfect" adjustment is necessary depends on the degree to which the magnetic compass will be relied upon in day-to-day navigation. If the magnetic compass is only used as a backup compass, removal of every last possible degree of error may not be worthwhile. If the magnetic compass is the only steering reference aboard, as is the case with many smaller commercial craft and fishing vessels, it should be adjusted as accurately as possible.

Prior to getting underway to swing ship, the navigator must ensure that the process will proceed as expeditiously as possible by preparing the vessel and compass. The following tests and adjustment can be done at dockside, assuming that the compass has been installed and maintained properly. Initial installation and adjustment should be done by a professional compass technician during commissioning.

1. Check for bubbles in the compass bowl. Fluid may be added through the filling plug if necessary. Large bubbles indicate serious leakage, indicating that the compass should be taken to a professional compass repair facility for new gaskets. It is important to note that not all commercially available compass fluids are compatible with all compasses, especial compasses that were original alcohol-filled. Very early fluid-filled compasses from the late 1800's were filled with a mixture of alcohol and water. Compass oil became more commonly used after the 1940s. If unsure about the type of fluid, it is advisable to contact a professional before adding any.
2. Check for free movement of gimbals. Clean any dust or dirt from gimbal bearings and lubricate them as recommended by the maker.
3. Check for magnetization of the quadrantal spheres by moving them close to the compass and rotating

them. If the compass needle moves more than 2 degrees, the spheres must be annealed to remove their magnetism. Annealing consists of heating the spheres to a dull red color in a non-magnetic area and allowing them to cool slowly to ambient temperature.

4. Check for magnetization of the Flinders bar by inverting it, preferably with the ship on an E/W heading. If the compass needle moves more than 2 degrees the Flinders bar must be annealed.
5. Synchronize the gyro repeaters with the master gyro so courses can be steered accurately.
6. Assemble past documentation relating to the compass and its adjustment. Have the ship's degaussing folder ready.
7. Ensure that every possible metallic object is stowed for sea. All guns, doors, booms, and other movable gear should be in its normal seagoing position. All gear normally turned on such as radios, radars, loudspeakers, etc. should be on while swinging ship.
8. Have the International Code flags Oscar-Quebec ready to fly.

Once underway to swing ship, the following procedures will expedite the process. Choose the best helmsman aboard and instruct him to steer each course as steadily and precisely as possible. Each course should be steered steadily for at least two minutes before any adjustments are made to remove Gaussin error. Be sure the gyro is set for the mean speed and latitude of the ship.

The navigator (or compass adjuster if one is employed) should have a pelorus and a table of azimuths prepared for checking the gyro, but the gyrocompass will be the primary steering reference. Normally the adjuster will request courses and move the magnets as he or she feels necessary, a process much more of an intuitive art than a science. If a professional adjuster is not available, use the following sequence:

1. If there is a sea running, steer course 000° and adjust the heeling magnet to decrease oscillations to a minimum.
2. Come to course 090°. When steady on course 090°, for at least two minutes, insert, remove, or move fore-and-aft B magnets to remove ALL deviation.
3. Come to a heading of 180°. Insert, remove, or move athwartships C magnets to remove ALL deviation.
4. Come to 270° and move the B magnets to remove one half of the deviation.
5. Come to 000° and move the C magnets to remove one half of the deviation.

6. Come to 045° (or any intercardinal heading) and move the quadrantal spheres toward or away from the compass to minimize any error.
7. Come to 135° (or any intercardinal heading 90° from the previous course) and move the spheres in or out to remove one half of the observed error.
8. Steer the ship in turn on each cardinal and intercardinal heading around the compass, recording the error at each heading called for on the deviation card. If plotted, the errors should plot roughly as a sine curve about the 0° line.

If necessary, repeat steps 1-8. There is no average error, for each ship is different, but generally speaking, errors of more than a few degrees, or errors which seriously distort the sine curve, indicate a magnetic problem which should be addressed.

Once the compass has been swung, tighten all fittings and carefully record the placement of all magnets and correctors. Finally, swing for residual degaussed deviations with the degaussing circuits energized and record the deviations on the deviation card. Post this card near the chart table for ready reference by the navigation team.

Once properly adjusted, the magnetic compass deviations should remain constant until there is some change in the magnetic condition of the vessel resulting from magnetic treatment, shock, vibration, repair, or structural changes. Transient deviations are discussed below.

810. Sources of Transient Error

The ship must be in seagoing trim and condition to properly compensate a magnetic compass. Any movement of large metal objects or the energizing of any electrical equipment in the vicinity of the compass can cause errors. If in doubt about the effect of any such changes, temporarily move the gear or cycle power to the equipment while observing the compass card while on a steady heading. Preferably this should be done on two different headings 90° apart, since the compass might be affected on one heading and not on another.

Some magnetic items which cause deviations if placed too close to the compass are as follows:

1. Movable guns or weapon loads
2. Magnetic cargo
3. Hoisting booms
4. Cable reels
5. Metal doors in wheelhouse
6. Chart table drawers
7. Movable gyro repeater
8. Windows and ports
9. Signal pistols racked near compass
10. Sound powered telephones
11. Magnetic wheel or rudder mechanism
12. Knives or tools near binnacle

HANDBOOK OF MAGNETIC
COMPASS ADJUSTMENT



NATIONAL
GEOSPATIAL-INTELLIGENCE AGENCY
BETHESDA, MD
20815



Figure 810. NGA Handbook of Magnetic Compass Adjustment (2004).

<https://msi.nga.mil/MSISiteContent/StaticFiles/HoMCA.pdf>

13. Watches, wrist bands, spectacle frames
14. Hat grommets, belt buckles, metal pencils
15. Heating of smoke stack or exhaust pipes
16. Landing craft

Some electrical items which cause variable deviations if placed too close to the compass are:

1. Electric motors
2. Magnetic controllers
3. Gyro repeaters
4. Nonmarried conductors
5. Loudspeakers
6. Electric indicators
7. Electric welding
8. Large power circuits
9. Searchlights or flashlights
10. Electrical control panels or switches
11. Telephone headsets
12. Windshield wipers
13. Rudder position indicators, solenoid type
14. Minesweeping power circuits
15. Engine order telegraphs
16. Radar equipment
17. Magnetically controlled switches
18. Radio transmitters
19. Radio receivers
20. Voltage regulators

Another source of transient deviation is the **retentive error**. This error results from the tendency of a ship's structure to retain induced magnetic effects for short periods of time. For example, a ship traveling north for several days, especially if pounding in heavy seas, will tend to retain some fore-and-aft magnetism induced under these conditions. Although this effect is transient, it may cause slightly incorrect observations or adjustments. This same type of error occurs when ships are docked on one heading for long periods of time. A

short shakedown, with the ship on other headings, will tend to remove such errors. A similar sort of residual magnetism is left in many ships if the degaussing circuits are not secured by the correct reversal sequence.

A source of transient deviation somewhat shorter in duration than retentive error is known as **Gaussin error**. This error is caused by eddy currents set up by a changing number of magnetic lines of force through soft iron as the ship changes heading. Due to these eddy currents, the induced magnetism on a given heading does not arrive at its normal value until about 2 minutes after changing course.

Deperming and other magnetic treatment will change

the magnetic condition of the vessel and therefore require compass readjustment. The decaying effects of deperming can vary. Therefore, it is best to delay readjustment for several days after such treatment. Since the magnetic fields used for such treatments are sometimes rather large at the compass locations, the Flinders bar, compass, and related equipment should be removed from the ship during these operations.

For more information on magnetic adjustment see NGA's Handbook of Magnetic Compass Adjustments via the link provided in Figure 810.

DEGAUSSING (MAGNETIC SILENCING) COMPENSATION

811. Degaussing

A steel vessel has a certain amount of **permanent magnetism** in its "hard" iron and **induced magnetism** in its "soft" iron. Whenever two or more magnetic fields occupy the same space, the total field is the vector sum of the individual fields. Thus, near the magnetic field of a vessel, the total field is the combined total of the Earth's field and the vessel's field. Not only does the Earth's field affect the vessel's, the vessel's field affects the Earth's field in its immediate vicinity.

Since certain types of explosive mines are triggered by the magnetic influence of a vessel passing near them, a vessel may use a degaussing system to minimize its magnetic field. One method of doing this is to neutralize each component of the field with an opposite field produced by electrical cables coiled around the vessel. These cables, when energized, counteract the permanent magnetism of the vessel, rendering it magnetically neutral. This has severe effects on magnetic compasses.

A unit sometimes used for measuring the strength of a magnetic field is the **gauss**. Reducing of the strength of a magnetic field decreases the number of gauss in that field. Hence, the process is called **degaussing**.

The magnetic field of the vessel is completely altered when the degaussing coils are energized, introducing large deviations in the magnetic compass. This deviation can be removed by introducing an equal and opposite force with energized coils near the compass. This is called **compass compensation**. When there is a possibility of confusion with compass adjustment to neutralize the effects of the natural magnetism of the vessel, the expression **degaussing compensation** is used. Since compensation may not be perfect, a small amount of deviation due to degaussing may remain on certain headings. This is the reason for swinging the ship with degaussing off and again with it on, and why there are two separate columns in the deviation table.

812. A Vessel's Magnetic Signature

A simplified diagram of the distortion of the Earth's magnetic field in the vicinity of a steel vessel is shown in Figure 812a. The field strength is directly proportional to the line spacing density. If a vessel passes over a device for detecting and recording the strength of the magnetic field, a certain pattern is traced. Figure 812b shows this pattern. Since the magnetic field of each vessel is different, each produces a distinctive trace. This distinctive trace is referred to as the vessel's **magnetic signature**.

Several **degaussing stations** have been established in major ports to determine magnetic signatures and recommend the current adjustments needed in the various degaussing coils to render the vessel magnetically neutral. Since a vessel's induced magnetism varies with heading and magnetic latitude, the current settings of the coils may sometimes need to be changed. A **degaussing folder** is provided to the vessel to indicate these changes and to document other pertinent information.

A vessel's permanent magnetism changes somewhat with time and the magnetic history of the vessel. Therefore, the data in the degaussing folder should be checked periodically at the magnetic station.

813. Degaussing Coils

For degaussing purposes, the total field of the vessel is divided into three components: (1) vertical, (2) horizontal fore-and-aft, and (3) horizontal athwartships. The positive (+) directions are considered downward, forward, and to port, respectively. These are the normal directions for a vessel headed north or east in north latitude.

Each component is opposed by a separate degaussing field just strong enough to neutralize it. Ideally, when this has been done, the Earth's field passes through the vessel smoothly and without distortion. The opposing degaussing fields are produced by direct current flowing in coils of wire. Each of the degaussing coils is placed so that the field it produces is directed to oppose one component of the ship's field.

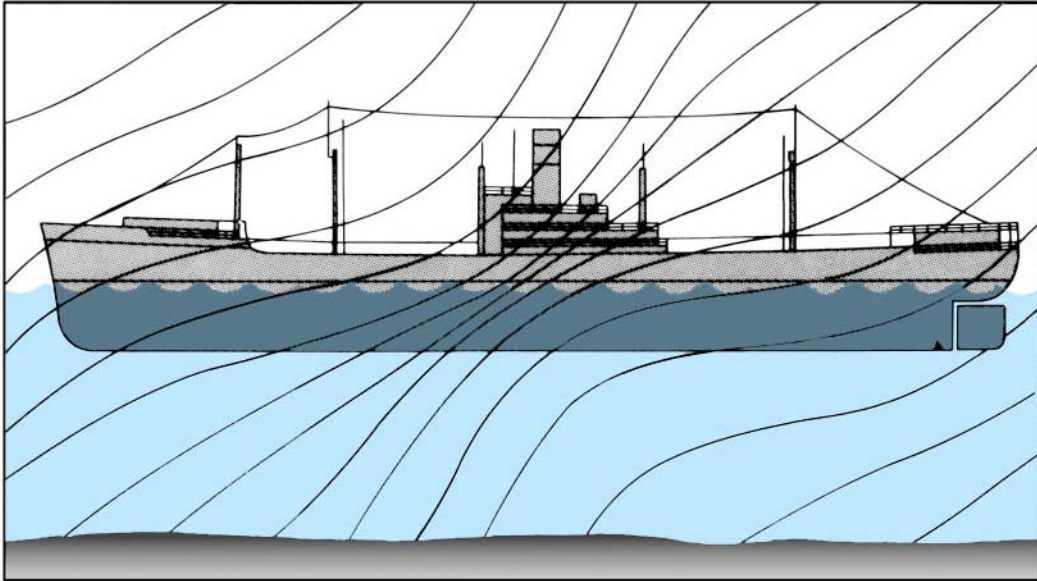

Figure 812a. Simplified diagram of distortion of Earth's magnetic field in the vicinity of a steel vessel.

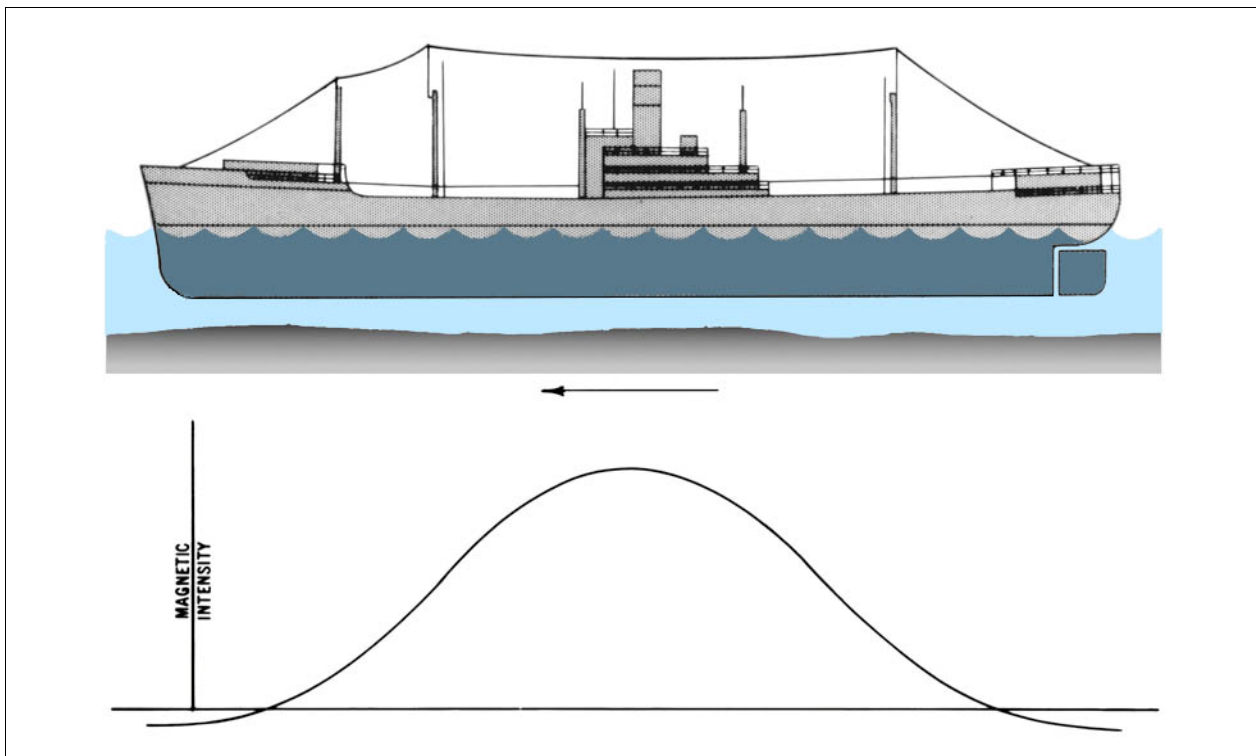

Figure 812b. A simplified signature of a vessel of Figure 812a.

The number of coils installed depends upon the magnetic characteristics of the vessel, and the degree of safety desired. The ship's permanent and induced magnetism may be neutralized separately so that control of induced magnetism can be varied as heading and latitude change, without disturbing the fields opposing the vessel's

permanent field. The principal coils employed are the following:

Main (M) coil. The M coil is horizontal and completely encircles the vessel, usually at or near the waterline. Its function is to oppose the vertical component of the vessel's combined permanent and induced fields.

Generally the induced field predominates. Current in the M-coil is varied or reversed according to the change of the induced component of the vertical field with latitude.

Forecastle (F) and quarterdeck (Q) coils. The F and Q coils are placed horizontally just below the forward and after thirds (or quarters), respectively, of the weather deck. These coils, in which current can be individually adjusted, remove much of the fore-and-aft component of the ship's permanent and induced fields. More commonly, the combined F and Q coils consist of two parts; one part the FP and QP coils, to take care of the permanent fore-and-aft field, and the other part, the FI and QI coils, to neutralize the induced fore-and-aft field. Generally, the forward and after coils of each type are connected in series, forming a split-coil installation and designated FP-QP coils and FI-QI coils. Current in the FP-QP coils is generally constant, but in the FI-QI coils is varied according to the heading and magnetic latitude of the vessel. In split-coil installations, the coil designations are often called simply the P-coil and I-coil.

Longitudinal (L) coil. Better control of the fore-and-aft components, but at greater installation expense, is provided by placing a series of vertical, athwartship coils along the length of the ship. It is the field, not the coils, which is longitudinal. Current in an L coil is varied as with the FI-QI coils. It is maximum on north and south headings, and zero on east and west headings.

Athwartship (A) coil. The A coil is in a vertical fore-and-aft plane, thus producing a horizontal athwartship field which neutralizes the athwartship component of the vessel's field. In most vessels, this component of the permanent field is small and can be ignored. Since the A-coil neutralizes the induced field, primarily, the current is changed with magnetic latitude and with heading, maximum on east or west headings, and zero on north or south headings.

The strength and direction of the current in each coil is indicated and adjusted at a control panel accessible to the navigator. Current may be controlled directly by rheostats at the control panel or remotely by push buttons which operate rheostats in the engine room.

Appropriate values of the current in each coil are determined at a degaussing station, where the various currents are adjusted until the vessel's magnetic signature is made as flat as possible. Recommended current values and directions for all headings and magnetic latitudes are set forth in the vessel's degaussing folder. This document is normally kept by the navigator, who must see that the recommended settings are maintained whenever the degaussing system is energized.

814. Securing the Degaussing System

Unless the degaussing system is properly secured, residual magnetism may remain in the vessel. During degaussing compensation and at other times, as

recommended in the degaussing folder, the "reversal" method is used. The steps in the reversal process are as follows:

1. Start with maximum degaussing current used since the system was last energized.
2. Decrease current to zero and increase it in the opposite direction to the same value as in step 1.
3. Decrease the current to zero and increase it to three-fourths maximum value in the original direction.
4. Decrease the current to zero and increase it to one-half maximum value in the opposite direction.
5. Decrease the current to zero and increase it to one-fourth maximum value in the original direction.
6. Decrease the current to zero and increase it to one-eighth maximum value in the opposite direction.
7. Decrease the current to zero and open switch.

815. Magnetic Treatment Of Vessels

In some instances, degaussing can be made more effective by changing the magnetic characteristics of the vessel by a process known as **deperming**. Heavy cables are wound around the vessel in an athwartship direction, forming vertical loops around the longitudinal axis of the vessel. The loops are run beneath the keel, up the sides, and over the top of the weather deck at closely spaced equal intervals along the entire length of the vessel. Predetermined values of direct current are then passed through the coils. When the desired magnetic characteristics have been acquired, the cables are removed.

A vessel which does not have degaussing coils, or which has a degaussing system that is inoperative, can be given some temporary protection by a process known as **flashing**. A horizontal coil is placed around the outside of the vessel and energized with large predetermined values of direct current. When the vessel has acquired a vertical field of permanent magnetism of the correct magnitude and polarity to reduce to a minimum the resultant field below the vessel for the particular magnetic latitude involved, the cable is removed. This type protection is not as satisfactory as that provided by degaussing coils because it is not adjustable for various headings and magnetic latitudes, and also because the vessel's magnetism slowly readjusts following treatment.

During magnetic treatment all magnetic compasses and Flinders bars should be removed from the ship. Permanent adjusting magnets and quadrantal correctors are not materially affected, and need not be removed. If it is impractical to remove a compass, the cables used for magnetic treatment should be kept as far as practical from it.

816. Degaussing Effects

The degaussing of ships for protection against magnetic influence mines creates additional effects upon magnetic compasses, which are somewhat different from

the permanent and induced magnetic effects. The degaussing effects are electromagnetic, and depend on:

1. Number and type of degaussing coils installed.
2. Magnetic strength and polarity of the degaussing coils.
3. Relative location of the different degaussing coils with respect to the binnacle.
4. Presence of masses of steel, which would tend to concentrate or distort magnetic fields in the vicinity of the binnacle.
5. The fact that degaussing coils are operated intermittently, with variable current values, and with different polarities, as dictated by necessary degaussing conditions.

817. Degaussing Compensation

The magnetic fields created by the degaussing coils would render the vessel's magnetic compasses useless unless compensated. This is accomplished by subjecting the compass to compensating fields along three mutually perpendicular axes. These fields are provided by small **compensating coils** adjacent to the compass. In nearly all installations, one of these coils, the **heeling coil**, is horizontal and on the same plane as the compass card, providing a vertical compensating field. Current in the heeling coil is adjusted until the vertical component of the total degaussing field is neutralized. The other compensating coils provide horizontal fields perpendicular to each other. Current is varied in these coils until their resultant field is equal and opposite to the horizontal component of the degaussing field. In early installations, these horizontal fields were directed fore-and-aft and athwartships by placing the coils around the Flinders bar and the quadrantal spheres. Compactness and other advantages are gained by placing the coils on perpendicular axes extending 045° - 225° and 315° - 135° relative to the heading. A frequently used compensating installation, called the **type K**, is shown in Figure 817. It consists of a heeling coil extending completely around the top of the binnacle, four **intercardinal coils**, and three control boxes. The intercardinal coils are named for their positions relative to the compass when the vessel is on a heading of north, and also for the compass headings on which the current in the coils is adjusted to the correct amount for compensation. The NE-SW coils operate together as one set, and the NW-SE coils operate as another. One control box is provided for each set, and one for the heeling coil.

The compass compensating coils are connected to the power supply of the degaussing coils, and the currents passing through the compensating coils are adjusted by series resistances so that the compensating field is equal to the degaussing field. Thus, a change in the degaussing currents is accompanied by a proportional change in the compensating currents. Each coil has a separate winding for each degaussing circuit it compensates.

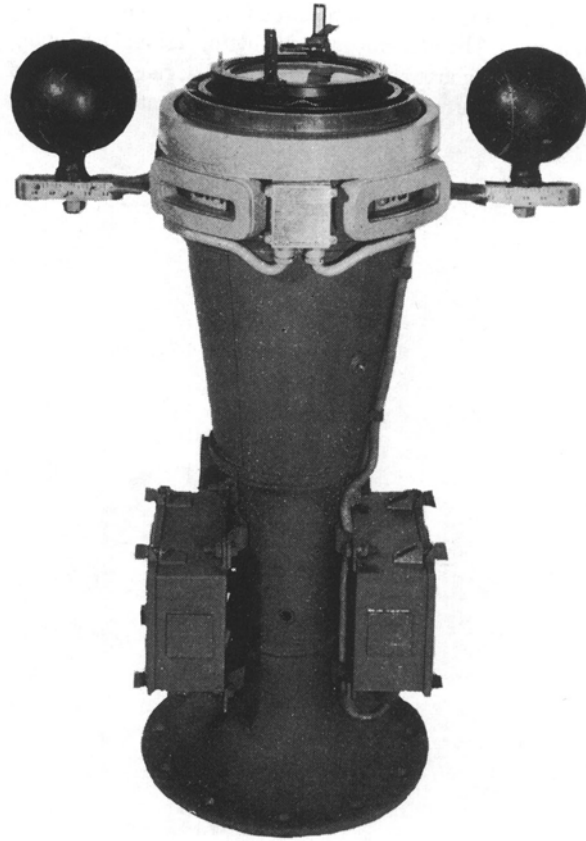

Figure 817. Type K degaussing compensation installation.

Degaussing compensation is carried out while the vessel is moored at the shipyard where the degaussing coils are installed. This process is usually carried out by civilian professionals, using the following procedure:

Step 1. The compass is removed from its binnacle and a dip needle is installed in its place. The M coil and heeling coil are then energized, and the current in the heeling coil is adjusted until the dip needle indicates the correct value for the magnetic latitude of the vessel. The system is then secured by the reversing process.

Step 2. The compass is replaced in the binnacle. With auxiliary magnets, the compass card is deflected until the compass magnets are parallel to one of the compensating coils or set of coils used to produce a horizontal field. The compass magnets are then perpendicular to the field produced by that coil. One of the degaussing circuits producing a horizontal field, and its compensating winding, are then energized, and the current in the compensating winding is adjusted until the compass reading returns to the value it had before the degaussing circuit was energized. The system is then secured by the reversing process. The process is repeated with each additional circuit used to create a horizontal field. The auxiliary magnets are then removed.

Step 3. The auxiliary magnets are placed so that the compass magnets are parallel to the other compensating coils or set of coils used to produce a horizontal field. The procedure of step 2 is then repeated for each circuit producing a horizontal field.

When the vessel gets under way, it proceeds to a suitable maneuvering area. The vessel is then steered so that the compass magnets are parallel first to one compensating coil or set of coils, and then the other. Any needed adjustment is made in the compensating circuits to reduce the error to a minimum. The vessel is then swung for residual deviation, first with degaussing off and then with degaussing on, and the correct current settings determined for each heading at the magnetic latitude of the vessel. From the values thus obtained, the "DG OFF" and "DG ON" columns of the deviation table are filled in. If the results indicate satisfactory compensation, a record is made of the degaussing coil settings and the resistance, voltages, and currents in the compensating coil circuits. The control boxes are then secured.

Under normal operating conditions, the settings do not need to be changed unless changes are made in the degaussing system, or unless an alteration is made in the

length of the Flinders bar or the setting of the quadrantal spheres. However, it is possible for a ground to occur in the coils or control box if the circuits are not adequately protected from moisture. If this occurs, it should be reflected by a change in deviation with degaussing on, or by a decreased installation resistance. Under these conditions, compensation should be done again. If the compass will be used with degaussing on before the ship can be returned to a shipyard where the compensation can be made by experienced personnel, the compensation should be made at sea on the actual headings needed, rather than by deflection of the compass needles by magnets. More complete information related to this process is given in the degaussing folder.

If a vessel has been given magnetic treatment, its magnetic properties have changed, necessitating readjustment of each magnetic compass. This is best delayed for several days to permit the magnetic characteristics of the vessel to settle. If compensation cannot be delayed, the vessel should be swung again for residual deviation after a few days. Degaussing compensation should not be made until after compass adjustment has been completed.

GYROCOMPASSES

818. Principles of the Gyroscope

A gyroscope consists of a spinning wheel or rotor contained within gimbals which permit movement about three mutually perpendicular axes, known as the **horizontal axis**, the **vertical axis**, and the **spin axis**. When spun rapidly, assuming that friction is not considered, the gyroscope develops **gyroscopic inertia**, tending to remain spinning in the same plane indefinitely. The amount of gyroscopic inertia depends on the angular velocity, mass, and radius of the wheel or rotor.

When a force is applied to change alignment of the spin axis of a gyroscope, the resultant motion is perpendicular to the direction of the force. This tendency is known as precession. A force applied to the center of gravity of the gyroscope will move the entire system in the direction of the force. Only a force that tends to change the axis of rotation produces precession.

If a gyroscope is placed at the equator with its spin axis pointing east-west, as the Earth turns on its axis, gyroscopic inertia will tend to keep the plane of rotation constant. To the observer, it is the gyroscope which is seen to rotate, not the Earth. This effect is called the horizontal earth rate, and is maximum at the equator and zero at the poles. At points between, it is equal to the cosine of the latitude.

If the gyro is placed at a geographic pole with its spin axis horizontal, it will appear to rotate about its vertical axis. This is the vertical earth rate. At all points between the equator and the poles, the gyro appears to turn partly about

its horizontal and partly about its vertical axis, being affected by both horizontal and vertical earth rates. In order to visualize these effects, remember that the gyro, at whatever latitude it is placed, is remaining aligned in space while the Earth moves beneath it.

819. Gyrocompass Operation

The gyrocompass depends upon four natural phenomena: gyroscopic inertia, precession, Earth's rotation, and gravity. To make a gyroscope into a gyrocompass, the wheel or rotor is mounted in a sphere, called the gyrosphere, and the sphere is then supported in a vertical ring. The whole is mounted on a base called the phantom. The gyroscope in a gyrocompass can be pendulous or non-pendulous, according to design. The rotor may weigh as little as half a kilogram to over 25 kg.

To make it seek and maintain true north, three things are necessary. First, the gyro must be made to stay on the plane of the meridian. Second, it must be made to remain horizontal. Third, it must stay in this position once it reaches horizontal regardless what the vessel on which it is mounted does or where it goes on the Earth. To make it seek the meridian, a weight is added to the bottom of the vertical ring, causing it to swing on its vertical axis, and thus seek to align itself horizontally. It will tend to oscillate, so a second weight is added to the side of the sphere in which the rotor is contained, which dampens the oscillations until the gyro stays on the meridian. With these two weights, the

only possible position of equilibrium is on the meridian with its spin axis horizontal.

To make the gyro seek north, a system of reservoirs filled with mercury, known as mercury ballistics, is used to apply a force against the spin axis. The ballistics, usually four in number, are placed so that their centers of gravity exactly coincide with the CG of the gyroscope. Precession then causes the spin axis to trace an ellipse, one ellipse taking about 84 minutes to complete. (This is the period of oscillation of a pendulum with an arm equal to the radius of the Earth.) To dampen this oscillation the force is applied, not in the vertical plane, but slightly to the east of the vertical plane. This causes the spin axis to trace a spiral instead of an ellipse and eventually settle on the meridian pointing north.

820. Gyrocompass Errors

The total of the all the combined errors of the gyrocompass is called **gyro error** and is expressed in degrees E or W, just like variation and deviation. But gyro error, unlike magnetic compass error, and being independent of Earth's magnetic field, will be constant in one direction; that is, an error of one degree east will apply to all bearings all around the compass.

The errors to which a gyrocompass is subject are speed error, latitude error, ballistic deflection error, ballistic damping error, quadrantal error, and gimbaling error. Additional errors may be introduced by a malfunction or incorrect alignment with the centerline of the vessel.

Speed error is caused by the fact that a gyrocompass only moves directly east or west when it is stationary (on the rotating Earth) or placed on a vessel moving exactly east or west. Any movement to the north or south will cause the compass to trace a path which is actually a function of the speed of advance and the amount of northerly or southerly heading. This causes the compass to tend to settle a bit off true north. This error is westerly if the vessel's course is northerly, and easterly if the course is southerly. Its magnitude depends on the vessel's speed, course, and latitude. This error can be corrected internally by means of a cosine cam mounted on the underside of the azimuth gear, which removes most of the error. Any remaining error is minor in amount and can be disregarded.

Tangent latitude error is a property only of gyros with mercury ballistics, and is easterly in north latitudes and westerly in south latitudes. This error is also corrected internally, by offsetting the lubber's line or with a small movable weight attached to the casing.

Ballistic deflection error occurs when there is a marked change in the north-south component of the speed. East-west accelerations have no effect. A change of course or speed also results in speed error in the opposite direction, and the two tend to cancel each other if the compass is properly designed. This aspect of design involves slightly offsetting the ballistics according to the operating latitude,

upon which the correction is dependent. As latitude changes, the error becomes apparent, but can be minimized by adjusting the offset.

Ballistic damping error is a temporary oscillation introduced by changes in course or speed. During a change in course or speed, the mercury in the ballistic is subjected to centrifugal and acceleration/deceleration forces. This causes a torquing of the spin axis and subsequent error in the compass reading. Slow changes do not introduce enough error to be a problem, but rapid changes will. This error is counteracted by changing the position of the ballistics so that the true vertical axis is centered, thus not subject to error, but only when certain rates of turn or acceleration are exceeded.

Quadrantal error has two causes. The first occurs if the center of gravity of the gyro is not exactly centered in the phantom. This causes the gyro to tend to swing along its heavy axis as the vessel rolls in the sea. It is minimized by adding weight so that the mass is the same in all directions from the center. Without a long axis of weight, there is no tendency to swing in one particular direction. The second source of quadrantal error is more difficult to eliminate. As a vessel rolls in the sea, the apparent vertical axis is displaced, first to one side and then the other. The vertical axis of the gyro tends to align itself with the apparent vertical. On northerly or southerly courses, and on easterly or westerly courses, the compass precesses equally to both sides and the resulting error is zero. On intercardinal courses, the N-S and E-W precessions are additive, and a persistent error is introduced, which changes direction in different quadrants. This error is corrected by use of a second gyroscope called a floating ballistic, which stabilizes the mercury ballistic as the vessel rolls, eliminating the error. Another method is to use two gyros for the directive element, which tend to precess in opposite directions, neutralizing the error.

Gimbaling error is caused by taking readings from the compass card when it is tilted from the horizontal plane. It applies to the compass itself and to all repeaters. To minimize this error, the outer ring of the gimbal of each repeater should be installed in alignment with the fore-and-aft line of the vessel. Of course, the lubber's line must be exactly centered as well.

821. Using the Gyrocompass

Since a gyrocompass is not influenced by magnetism, it is not subject to variation or deviation. Any error is constant and equal around the horizon, and can often be reduced to less than one degree, thus effectively eliminating it altogether. Unlike a magnetic compass, it can output a signal to repeaters spaced around the vessel at critical positions.

But it also requires a constant source of stable electrical power, and if power is lost, it requires several hours to settle on the meridian again before it can be used. This period can

be reduced by aligning the compass with the meridian before turning on the power.

The directive force of a gyrocompass depends on the amount of precession to which it is subject, which in turn is dependent on latitude. Thus the directive force is maximum at the equator and decreases to zero at the poles. Vessels operating in high latitudes must construct error curves based on latitudes because the errors at high latitudes eventually overcome the ability of the compass to correct them.

The gyrocompass is typically located below decks as close as possible to the center of roll, pitch and yaw of the ship, thus minimizing errors caused by the ship's motion.

Repeaters are located at convenient places throughout the ship, such as at the helm for steering, on the bridge wings for taking bearings, in after steering for emergency steering, and other places. The output can also be used to drive course recorders, autopilot systems, plotters, fire control systems, and stabilized radars. The repeaters should be checked regularly against the master to ensure they are all in alignment. The repeaters on the bridge wing used for taking bearings will likely be equipped with removable bearing circles, azimuth circles, and telescopic alidades, which allow one to sight a distant object and see its exact gyrocompass bearing.

ELECTRONIC COMPASSES

822. New Direction Sensing Technologies

The magnetic compass has considerable limitations, chiefly that of being unable to isolate the earth's magnetic field from all others close enough to influence it. It also indicates magnetic north, whereas the mariner is most interested in true north. Most of the work involved with compensating a traditional magnetic compass involves neutralizing magnetic influences other than the Earth's, a complicated and inexact process often involving more art than science. Residual error is almost always present even after compensation. Degaussing complicates the situation immensely.

The electro-mechanical gyrocompass has been the standard steering and navigational compass since the early 20th century, and has provided several generations of mariners a stable and reliable heading and bearing reference. However, it too has limitations: It is a large, expensive, heavy, sensitive device that must be mounted according to rather strict limitations. It requires a stable and uninterrupted supply of electrical power; it is sensitive to shock, vibration, and environmental changes; and it needs several hours to settle after initialization.

Fortunately, several new technologies have been developed which promise to greatly reduce or eliminate the complications brought on by the limitations of both the mechanical gyroscope and traditional magnetic compasses. Sometimes referred to as "electronic compasses," the digital flux gate magnetic compass and the ring laser gyrocompass are two such devices. They have the following advantages:

1. Solid state electronics, no moving parts
2. Operation at very low power
3. Easy backup power from independent sources
4. Standardized digital output
5. Zero friction, drift, or wear
6. Compact, lightweight, and inexpensive
7. Rapid start-up and self-alignment

8. Low sensitivity to vibration, shock, and temperature changes
9. Self-correcting

Both types are being installed in many vessels as the primary directional reference, enabling the decommissioning of the traditional magnetic compasses and the avoidance of periodic compensation and maintenance.

823. The Flux Gate Compass

The most widely used sensor for digital compasses is the flux-gate magnetometer, developed around 1928. Initially it was used for detecting submarines, for geophysical prospecting, and airborne mapping of Earth's magnetic fields.

The most common type, called the second harmonic device, incorporates two coils, a primary and a secondary, both wrapped around a single highly permeable ferromagnetic core. In the presence of an external magnetic field, the core's magnetic induction changes. A signal applied to the primary winding causes the core to oscillate. The secondary winding emits a signal that is induced through the core from the primary winding. This induced signal is affected by changes in the permeability of the core and appears as an amplitude variation in the output of the sensing coil. The signal is then demodulated with a phase-sensitive detector and filtered to retrieve the magnetic field value. After being converted to a standardized digital format, the data can be output to numerous remote devices, including steering compasses, bearing compasses, emergency steering stations, and autopilots.

Since the influence of a ship's inherent magnetism is inversely proportional to the square of the distance to the compass, it is logical that if the compass could be located at some distance from the ship, the influence of the ship's magnetic field could be greatly reduced. One advantage of the flux gate compass is that the sensor can be located

remotely from the readout device, allowing it to be placed at a position as far as possible from the hull and its contents, such as high up on a mast, the ideal place for most vessels.

A further advantage is that the digital signal can be processed mathematically, and algorithms written which can correct for observed deviation once the deviation table has been determined. Further, the "table," in digital format, can be found by merely steering the vessel in a full circle. Algorithms then determine and apply corrections that effectively flatten the usual sine wave pattern of deviation. The theoretical result is zero observed compass deviation.

Should there be an index error (which has the effect of skewing the entire sine wave below or above the zero degree axis of the deviation curve) this can be corrected with an index correction applied to all the readings. This problem is largely confined to asymmetric installations such as aircraft carriers. Similarly, a correction for variation can be applied, and with GPS input (so the system knows where it is with respect to the isogonic map) the variation correction can be applied automatically, thus rendering the output in true degrees, corrected for both deviation and variation.

It is important to remember that a flux gate compass is still a magnetic compass, and that it will be influenced by large changes to the ship's magnetic field. Compensation should be accomplished after every such change. Fortunately, as noted, compensation involves merely steering the vessel in a circle in accordance with the manufacturer's recommendations.

Flux-gate compasses from different manufacturers share some similar operational modes. Most of them will have the following:

SET COURSE MODE: A course can be set and "remembered" by the system, which then provides the helmsman a graphic steering aid, enabling him to see if the ship's head is right or left of the set course, as if on a digital "highway." Normal compass operation continues in the background.

DISPLAY RESPONSE DAMPING: In this mode, a switch is used to change the rate of damping and update of the display in response to changes in sea condition and vessel speed.

AUTO-COMPENSATION: This mode is used to determine the deviation curve for the vessel as it steams in a complete circle. The system will then automatically compute correction factors to apply around the entire compass, resulting in zero deviation at any given heading. This should be done after every significant change in the magnetic signature of the ship, and within 24 hours of entering restricted waters.

CONTINUOUS AUTO-COMPENSATION: This mode, which should normally be turned OFF in restricted waters and ON at sea, runs the compensation algorithm each time the ship completes a 360 degree turn in two minutes. A warning flashes on the display in the OFF mode.

PRE-SET VARIATION: In effect an index correction, pre-set variation allows the application of magnetic variation to the heading, resulting in a true output (assuming the unit has been properly compensated and aligned). Since variation changes according to one's location on the Earth, it must be changed periodically to agree with the charted variation unless GPS input is provided. The GPS position input is used in an algorithm which computes the variation for the area and automatically corrects the readout.

U.S. Naval policy approves the use of flux gate compasses and the lay-up, but not the removal of the traditional binnacle mounted compass, which should be clearly marked as "Out of Commission" once an approved flux gate compass has been properly installed and tested.

824. Optical Gyroscopes

Optical gyroscope use can be classified under two major types: ring laser gyroscope (RLG) and fiber optic gyroscope (FOG). Both of these sensors make use of French Physicist Georges Sagnac's observation of rotation relative to inertial space thus bearing the name, Sagnac Effect. This principle states that if two beams of light are sent in opposite directions around a "ring" or polyhedron and steered so as to meet and combine, a standing wave will form around the ring. If the wave is observed from any point, and that point is then moved along the perimeter of the ring, the wave form will change in direct relationship to the direction and velocity of movement. While Sagnac's work was in pursuit of identifying the "ether" that was postulated in the late 19th century as the medium that supported the propagation of light waves, the effect that he predicted and measured was found to be rooted in general relativity. Sagnac is given significant credit, because he was the first person to report the experimental observation for a polygonal interferometer mounted on a turn-table. The practical realization of a Sagnac interferometer as a rotation sensor came only after the invention of the laser and other optical components. The Sagnac interferometer can be implemented in a resonant cavity as in the case of the RLG or in a non-resonant interferometer configuration of which the commercially available FOG is an example. While it is true that a FOG can be configured as a resonant cavity, this type of device has not yet achieved commercial success and will not be described herein.

825. The Ring Laser Gyrocompass

The ring laser had its beginnings in England, where in the 1890's two scientists, Joseph Larmor and Sir Oliver Lodge (also one of the pioneers of radio), debated the possibility of measuring rotation by a ring interferometer. Following Sagnac's 1913 observation. It wasn't until 1963 that D. T. M. Davis Jr. and W. Macek of Sperry-Rand Corporation tested and refined the concept into a useful

research device. Initially, mirrors were used to direct light around a square or rectangular pattern. But such mirrors must be made and adjusted to exceptionally close tolerances to allow useful output, and must operate in a vacuum for best effect. Multilayer dielectric mirrors with a reflectivity of 99.9999 percent were developed. The invention of laser light sources and fiber-optics has enabled the production of small, light, and dependable ring laser gyros. Mirror-based devices continue to be used in physics research.

The ring laser gyrocompass (RLG) operates by measuring laser-generated light waves traveling around a fiber-optic ring. A beam splitter divides a beam of light into two counter-rotating waves, which then travel around the fiber-optic ring in opposite directions. The beams are then recombined and sent to an output detector. In the absence of rotation, the path lengths will be the same and the beams will recombine in phase. If the device has rotated, there will be a difference in the length of the paths of the two beams, resulting in a detectable phase difference in the combined signal. The signal will vary in amplitude depending on the amount of the phase shift. The amplitude is thus a measurement of the phase shift, and consequently, the rotation rate. This signal is processed into a digital readout in degrees. This readout, being digital, can then be sent to a variety of devices which need heading information, such as helm, autopilot, and electronic chart systems.

A single ring laser gyroscope can be used to provide a one-dimensional rotational reference, exactly what a compass needs. The usefulness of ring laser gyrocompasses is clear in that they share many of the same characteristics of flux gate compasses. They are compact, light, inexpensive, accurate, dependable, and robust. The ring laser device is also unaffected by magnetic influences that would certainly impact the traditional compass, and even such that might adversely affect a remotely mounted flux gate compass.

Ring laser gyroscopes can also serve as the stable elements in an inertial guidance system, using three gyros to represent the three degrees of freedom, thus providing both directional and position information. The principle of operation is the same as for mechanical inertial navigation devices, in that a single gyro can measure any rotation about its own axis. This implies that its orientation in space about its own axis will be known at all times. Three gyros arranged along three axes each at 90 degrees to the others can measure accelerations in three dimensional space, and thus track movement over time.

Inertial navigation systems based on ring lasers have been used in aircraft for a number of years, and are becoming increasingly common in maritime applications. Uses include navigation, radar and fire control systems, precise weapons stabilization, and stabilization of directional sensors such as satellite antennas.

826. The Fiber Optic Gyro

A non-resonant Sagnac interferometer is used as the basis of what is referred to as the interferometric fiber optic gyro (IFOG) often shortened to simply FOG. Resonant fiber optic gyros have been developed but at this time have not become commercially practical.

The development of the FOG required its own enabling technology, namely low loss, single mode optical fibers that became available in the mid-1970s. Vali and Shorthill first proposed the fiber optic gyro in 1975. The FOG is composed of a light source, a coupler, a fiber coil and a detector. Light is launched from the source and coupled through a fiber optic coil in both the clockwise and counter-clockwise directions. Based on the Sagnac effect, the optical path seen by the two beams interfere and the intensity detected is a function of the phase difference and hence the angular rate of the gyro.

The interferometric architecture of the FOG has a poor sensitivity at low rates as due to cosine nature of the phase difference and near zero phase at the peak of the cosine function. To achieve better sensitivity, it is necessary to modulate the light which is accomplished in modern FOG configurations through the use of an electro-optic phase modulator. Light passing through the modulator is phase shifted in proportion to the applied voltage. Differential phase shifts between the clockwise and counter-clockwise beams are sustained for only one transit time of the light through the coil and thus the modulation must be applied every transit time.

Phase modulation of the light improves the sensitivity at low angular rates. However, the high rate non-linearity, light intensity variation, photo-detector sensitivity, preamp gain and background intensity all affect the open loop output of the FOG. For this reason, it is important for higher accuracy and greater dynamic range to operate the FOG in a closed loop fashion. The same device that accomplished the phase shifting of the light is typically used to close the loop in the FOG. Because the angular rate sensed by the FOG appears as an interferometer phase shift, it may be nulled out by applying a phase rebalance in addition to the phase shift with the modulator. A complication arises due to the fact that the modulator can produce a differential phase shift between clockwise and counter-clockwise light beams only during the transit time of the light through the fiber coil and a given angular rate produces a persistent phase shift between the light beams. To achieve phase nulling, it is necessary to increase the phase applied at every transit time. A periodic reset is required when the maximum voltage that is supplied to the modulator is reached. The magnitude of this reset must be exactly $2(\pi)$ to avoid introducing a gyro error.

The sensitivity of the FOG is theoretically limited by the photon shot noise which emerges from the statistical distribution of energy of the photon impinging on the photo detector. While the Sagnac sensitivity increases with the

length of the fiber, the photon energy decreases with fiber length due to attenuation of the light as it travels through the fiber. Thus a tradeoff must be done when choosing the size of the FOG for a given application. Errors in the FOG output arise through a number of sources. Rayleigh backscattering is the dominant error source in the FOG. This comes about when backscatter of one beam interferes with the other light beam. Low coherence light sources are used to reduce this effect. Two popular light sources for FOGs are the superluminescent diode (SLD) and the broadband fiber source (BFS). The change in the index of refraction of the fiber as a function of the intensity of the light induces an error through the optical Kerr effect. This effect is also reduced through the use of low coherence light sources. The thermal gradient effect due to uneven heating of the fiber coil is typically the major challenge to achieving required performance in the FOG. The light beam will experience propagation delays due to temperature differences along the length of the fiber. These propagation delays are not the same for the two counter propagating beams which results in a gyro error. Sophisticated coil winding designs, such as quadrupole or octopole can help to minimize this effect. Finally, birefringence effects, from the fiber, can result in errors; good control of the light polarization is required.

The FOG has gained a wide acceptance and is found in a wide variety of applications from undersea to outer space. The performance of the FOG as a gyro is dependent primarily on the diameter of the fiber coil and the length of the fiber. Thus the size of the FOG can vary significantly from coil diameters of approximately an inch with less than 100 meters of fiber to diameters of several inches containing multiple kilometers of fiber depending on the application and performance requirement. The FOG has been shown to have better reliability than that of the RLG and further eliminates the need for any high voltages that are required to initiate and maintain the plasma in the RLG. For these reasons, the marketplace is moving from RLG to FOG. Also, while there are only a few manufacturers of RLG left around the globe, and it is estimated that there may be more than a dozen manufacturers of FOG based systems worldwide.

827. The Hemispherical Resonator Gyro

The Hemispherical Resonator Gyro (HRG) belongs to a class of gyros referred to as Coriolis Vibratory Gyros (CVG). The physics of the HRG is based on the forces arising from the Coriolis Effect which describes the motion of a body undergoing uniform motion in a rotating frame of reference. The HRG was conceived in 1890 when physicist G.H. Bryan struck a wineglass, making an interesting discovery of how the tone from a glass behaved when it was rotated about its stem. To understand the operation of an HRG, consider a thin hemispherical shell, although other suitable configurations can also be used, such as

cylindrical, whereas the rim of the shell can be made to vibrate by applying appropriate force and technique. The lowest fundamental mode is characterized by four nodes and four antinodes of vibration. The rim of the shell will then have a radial velocity component at the antinodes and a tangential velocity component at the nodes.

When the shell is subject to an angular rate about its sensitive axis, which is perpendicular to the plane of the standing wave pattern, Coriolis forces are generated. These forces are proportional to the applied angular rate and are orthogonal to both the applied rate vector and the shell's velocity vectors. The result of these forces is standing wave whose nodes and antinodes are now shifted with respect to the original pattern. The superposition of the original wave and the new orthogonal wave result in a phenomenon in which the resultant wave rotates relative to its own casing and to inertial space through an angle that is proportional to the angular rotation of the gyro case. The resultant pattern precesses in the opposite sense. The angular gain factor is a function of the geometrical design and provides a very stable gyro scale factor. The electrical sensing of pattern is typically accomplished through capacitive elements that are implemented between the shell and another element separated from the shell by a suitable gap.

The HRG is attractive as a result of the very low noise figure, one or two order of magnitude better than what can be achieved with either an RLG or FOB of comparable design. Furthermore, due to the simplistic nature of the sensing element, the HRG has realized extraordinary reliability with tens of millions of failure-free operations exhibited in space applications. The challenges with the HRG are also related to the simplicity of the sensing element since that results in complexity of the electronics required for operation, HRG electronic functions are broadly grouped into the following categories:

1. Reference phase generation and frequency control
2. Amplitude control
3. Pattern angle readout
4. Quadrature suppression
5. Force-to-rebalance mode of operation
6. Whole angle mode of operation

In the force-to-rebalance mode of operation, the nodes and antinodes are capacitively held in place. The capacitive force required to do this is a measure of the angular rate experienced by the HRG. In this mode of operation, the bias errors can be minimized; however, the gyro scale factor is a function of the electronics and temporal trends in scale factor are observed as the electronics age. The force-to-rebalance mode is limited by the available capacitive forcing. This limits the angular rate range typically to less than 100 deg/sec for practical devices. In the whole angle mode of operation, the pattern is allowed to precess and so the angular rate range is limited only by the processing electronics. As mentioned, the geometric scale factor is very stable and hence scale factor performance of the HRG is excellent in the whole angle mode; however, the bias performance tends not to be as good as in the force-to-rebalance mode.

CORRECTING AND UNCORRECTING THE COMPASS

828. Ship’s Heading

Ship’s heading is the angle, expressed in degrees clockwise from north, of the ship’s fore-and-aft line with respect to the true meridian or the magnetic meridian. When this angle is referred to the true meridian, it is called a **true heading**. When this angle is referred to the magnetic meridian, it is called a **magnetic heading**. Heading, as indicated on a particular compass, is termed the ship’s compass heading by that compass. It is essential to specify every heading as true (T), magnetic (M), or compass. Two abbreviations simplify recording of compass directions. The abbreviation PGC refers to “per gyro compass,” and PSC refers to “per steering compass.” The steering compass is the one being used by the helmsman or autopilot, regardless of type.

829. Variation and Deviation

Variation is the angular measure between the magnetic meridian and the true meridian at a given location. If the northerly part of the magnetic meridian lies to the right of the true meridian, the variation is easterly. Conversely, if this part is to the left of the true meridian, the variation is westerly. The local variation and its small **annual change** are noted on the compass rose of all navigational charts. Thus the true and magnetic headings of a ship differ by the local variation.

As previously explained, a ship’s magnetic influence will generally cause the compass needle to deflect from the magnetic meridian. This angle of deflection is called **deviation**. If the north end of the needle points east of the magnetic meridian, the deviation is easterly; if it points west of the magnetic meridian, the deviation is westerly.

830. Heading Relationships

A summary of heading relationships follows:

1. **Deviation** is the difference between the compass heading and the magnetic heading.

2. **Variation** is the difference between the magnetic heading and the true heading.
3. The algebraic sum of deviation and variation is the **compass error**.

The following simple rules will assist in correcting and uncorrecting the compass:

1. Compass least, error east; compass best, error west.
2. When correcting, add easterly errors, subtract westerly errors (Remember: “Correcting Add East”).
3. When uncorrecting, subtract easterly errors, add westerly errors.

Some typical correction operations follow:

<u>Compass</u>	<u>Deviation</u>	<u>Magnetic</u>	<u>Variation</u>	<u>True</u>
		-> +E, -W		
358°	5°E	003°	6°E	009°
120°	1°W	119°	3°E	122°
180°	6°E	186°	8°W	178°
240°	5°W	235°	7°W	228°
		+W, -E <-		

Figure 830. Examples of compass correcting.

Use the memory aid “Can Dead Men Vote Twice, At Elections” to remember the conversion process (Compass, Deviation, Magnetic, Variation, True; Add East). When converting compass heading to true heading, add easterly deviations and variations and subtract westerly deviations and variations. “Truly Valiant Marines Don’t Cry at Weddings” is another phrase used to remember compass correction where Westerly error is added.

The same rules apply to correcting gyrocompass errors, although gyro errors always apply in the same direction. That is, they are E or W all around the compass.

Complete familiarity with the correcting of compasses is essential for navigation by magnetic or gyro compass. Professional navigators who deal with them continually can correct them in their heads quickly and accurately.