

# APPENDICES

APPENDIX A.	THE WORLD SAILING SHIP ROUTES .....	705
APPENDIX B.	CALCULATIONS AND CONVERSIONS .....	707
APPENDIX C.	SATELLITE NAVIGATION .....	721





# THE WORLD SAILING SHIP ROUTES

PREPARED BY REAR ADMIRAL BOYLE T. SOMERVILLE, C.M.G.

## NOTES

The routes were first generally used by Sailing Ships on Ocean Voyages during the Sailing Ship Era. Since no sailing vessels are now shown, the routes shown are merely to illustrate the example. From Bombay to Aden in S.E. Asia, as shown at those ports, obtain trade by Sailing Ships.

North-going routes are tinted Brown  
South-going routes are tinted Purple  
East-going routes are tinted Blue  
West-going routes are tinted Magenta

The colored route areas indicate that favorable trade winds which tracks were usually made. Where the route between two ports changes according to the season, the track for the appropriate period is named. The "oblique" tracks shown are those performed by some navigators, instead of the routes in general use.

The routes shown are based on general experience but owing to the variability of winds and currents small alterations may be necessary to depart from the tracks recommended here.

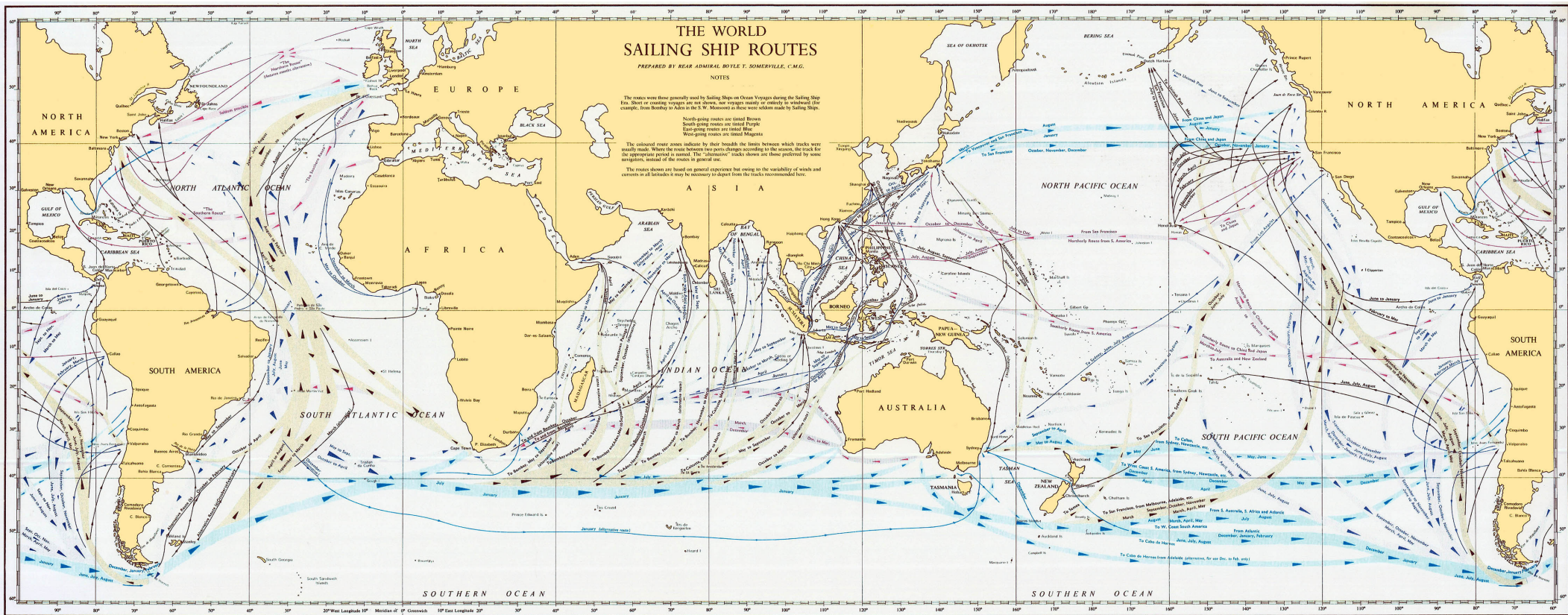





# APPENDIX B

## CALCULATIONS AND CONVERSIONS

### INTRODUCTION

#### App B 1. Purpose and Scope

This chapter discusses the use of calculators and computers in navigation and summarizes the formulas the navigator depends on during voyage planning, piloting, celestial navigation, and various related tasks. To fully utilize this chapter, the navigator should be competent in basic mathematics including algebra and trigonometry (See [Chapter 1 - Mathematics in Volume II](#)) and be familiar with the use of a basic scientific calculator. The navigator should choose a calculator based on personal needs, which may vary greatly from person to person according to individual abilities and responsibilities.

#### App B 2. Use of Calculators in Navigation

Any common calculator can be used in navigation, even one providing only the four basic arithmetic functions of addition, subtraction, multiplication, and division. Any good scientific calculator can be used for sight reduction, sailings, and other tasks. However, the use computer applications and handheld calculators specifically designed for navigation will greatly reduce the workload of the navigator, reduce the possibility of errors, and assure accuracy of the results calculated.

Calculations of position based on celestial observations have become increasingly uncommon since the advent of GPS as a dependable position reference for all modes of navigation. This is especially true since GPS units provide worldwide positioning with far greater accuracy and reliability than celestial navigation.

However, for those who use celestial techniques, a celestial navigation calculator or computer application can improve celestial position accuracy by easily solving numerous sights, and by reducing mathematical and tabular errors inherent in the manual sight reduction process. They can also provide weighted plots of the LOP's from any number of celestial bodies, based on the navigator's subjective analysis of each sight, and calculate the best fix with latitude/longitude readout.

In using a calculator for any navigational task, it is important to remember that the accuracy of the result, even if carried out many decimal places, is only as good as the least accurate entry. If a sextant observation is taken to an accuracy of only a minute, that is the best accuracy of the final

solution, regardless the calculator's ability to solve to 12 decimal places. See [Chapter 3 - Navigational Error in Volume II](#) for a discussion of the sources of error in navigation.

Some basic calculators require the conversion of degrees, minutes and seconds (or tenths) to decimal degrees before solution. A good navigational calculator, however, should permit entry of degrees, minutes and tenths of minutes directly, and should do conversions automatically. Though many non-navigational computer programs have an on-screen calculator, they are generally very simple versions with only the four basic arithmetical functions. They are thus too simple for complex navigational problems. Conversely, a good navigational computer program requires no calculator per se, since the desired answer is calculated automatically from the entered data.

The following articles discuss calculations involved in various aspects of navigation.

#### App B 3. Calculations of Piloting

- **Hull speed in knots** is found by:

$$S = 1.34\sqrt{\text{waterline length (in feet)}}$$

This is an approximate value which varies with hull shape.

- **Nautical and U.S. survey miles** can be interconverted by the relationships:

$$1 \text{ nautical mile} = 1.15077945 \text{ U.S. survey miles.}$$

$$1 \text{ U.S. survey mile} = 0.86897624 \text{ nautical miles.}$$

- **The speed of a vessel over a measured mile** can be calculated by the formula:

$$S = \frac{3600}{T}$$

where S is the speed in knots and T is the time in seconds.

- **The distance traveled at a given speed** is computed

by the formula:

$$D = \frac{ST}{60}$$

where D is the distance in nautical miles, S is the speed in knots, and T is the time in minutes.

- **Distance to the visible horizon in nautical miles** can be calculated using the formula:

$$D = 1.17 \sqrt{h_f}, \text{ or}$$

$$D = 2.07 \sqrt{h_m}$$

depending upon whether the height of eye of the observer above sea level is in feet ( $h_f$ ) or in meters ( $h_m$ ).

- **Dip of the visible horizon in minutes of arc** can be calculated using the formula:

$$D = 0.97' \sqrt{h_f}, \text{ or}$$

$$D = 1.76' \sqrt{h_m}$$

depending upon whether the height of eye of the observer above sea level is in feet ( $h_f$ ) or in meters ( $h_m$ ).

- **Distance to the radar horizon in nautical miles** can be calculated using the formula:

$$D = 1.22 \sqrt{h_f}, \text{ or}$$

$$D = 2.21 \sqrt{h_m}$$

depending upon whether the height of the antenna above sea level is in feet ( $h_f$ ) or in meters ( $h_m$ ).

- **Dip of the sea short of the horizon** can be calculated using the formula:

$$Ds = 60 \tan^{-1} \left( \frac{h_f}{6076.1 d_s} + \frac{d_s}{8268} \right)$$

where Ds is the dip short of the horizon in minutes of arc;  $h_f$  is the height of eye of the observer above sea level, in feet and  $d_s$  is the distance to the waterline of the object in nautical miles.

- **Distance by vertical angle between the waterline and the top of an object** is computed by solving the right triangle formed between the observer, the top of the object, and the waterline of the object by simple trigonometry. This assumes that the observer is at sea level, the Earth is flat between observer and object,

there is no refraction, and the object and its waterline form a right angle. For most cases of practical significance, these assumptions produce no large errors.

$$D = \sqrt{\frac{\tan^2 a}{0.0002419^2} + \frac{H-h}{0.7349}} - \frac{\tan a}{0.0002419}$$

where D is the distance in nautical miles, a is the corrected vertical angle, H is the height of the top of the object above sea level, and h is the observer's height of eye in feet. The constants (0.0002419 and 0.7349) account for refraction.

#### App B 4. Tide Calculations

- **The rise and fall of a diurnal tide** can be roughly calculated from the following table, which shows the fraction of the total range the tide rises or falls during flood or ebb.

Hour	Amount of flood/ebb
1	1/12
2	2/12
3	3/12
4	3/12
5	2/12
6	1/12

#### App B 5. Calculations of Celestial Navigation

Unlike sight reduction by tables, sight reduction by calculator permits the use of nonintegral values of latitude of the observer, and LHA and declination of the celestial body. Interpolation is not needed, and the sights can be readily reduced from any assumed position. Simultaneous, or nearly simultaneous, observations can be reduced using a single assumed position. Using the observer's DR or MPP for the assumed longitude usually provides a better representation of the circle of equal altitude, particularly at high observed altitudes.

- **The dip correction** is computed in the *Nautical Almanac* using the formula:

$$D = 0.97 \sqrt{h}$$

where dip is in minutes of arc and h is height of eye in feet. This correction includes a factor for refraction. The *Air Almanac* uses a different formula intended for air navigation. The differences are of no significance in practical navigation.

- **The computed altitude ( $H_c$ )** is calculated using the basic formula for solution of the undivided navigational

triangle:

$$\sin h = \sin L \sin d + \cos L \cos d \cos LHA,$$

in which h is the altitude to be computed (Hc), L is the latitude of the assumed position, d is the declination of the celestial body, and LHA is the local hour angle of the body. Meridian angle (t) can be substituted for LHA in the basic formula.

Restated in terms of the inverse trigonometric function:

$$Hc = \sin^{-1} [(\sin L \sin d) + (\cos L \cos d \cos LHA)].$$

When latitude and declination are of contrary name, declination is treated as a negative quantity. No special sign convention is required for the local hour angle, as in the following azimuth angle calculations.

- **The azimuth angle (Z)** can be calculated using the altitude azimuth formula if the altitude is known. The formula stated in terms of the inverse trigonometric function is:

$$Z = \cos^{-1} \left( \frac{\sin d - (\sin L \sin Hc)}{\cos L \cos Hc} \right)$$

If the altitude is unknown or a solution independent of altitude is required, the azimuth angle can be calculated using the time azimuth formula:

$$Z = \tan^{-1} \left( \frac{\sin LHA}{(\cos L \tan d) - (\sin L \cos LHA)} \right)$$

The sign conventions used in the calculations of both azimuth formulas are as follows: (1) if latitude and declination are of contrary name, declination is treated as a negative quantity; (2) if the local hour angle is greater than 180°, it is treated as a negative quantity.

If the azimuth angle as calculated is negative, add 180° to obtain the desired value.

- **Amplitudes** can be computed using the formula:

$$A = \sin^{-1}(\sin d \sec L)$$

this can be stated as

$$A = \sin^{-1} \left( \frac{\sin d}{\cos L} \right)$$

where A is the arc of the horizon between the prime vertical and the body, L is the latitude at the point of observation, and d is the declination of the celestial body.

### App B 6. Calculations of the Sailings

- **Plane sailing** is based on the assumption that the me-

ridian through the point of departure, the parallel through the destination, and the course line form a plane right triangle, as shown in Figure B6.

$$\text{From this: } \cos C = \frac{l}{D}, \sin C = \frac{p}{D}, \text{ and } \tan C = \frac{p}{l}.$$

$$\text{From this: } l = D \cos C, D = l \sec C, \text{ and } p = D \sin C.$$

From this, given course and distance (C and D), the difference of latitude (l) and departure (p) can be found, and given the latter, the former can be found, using simple trigonometry. See [Chapter 12 - The Sailings, Volume I](#).

- **Traverse sailing** combines plane sailings with two or more courses, computing course and distance along a series of rhumb lines. See [Chapter 12 - The Sailings, Volume I](#).

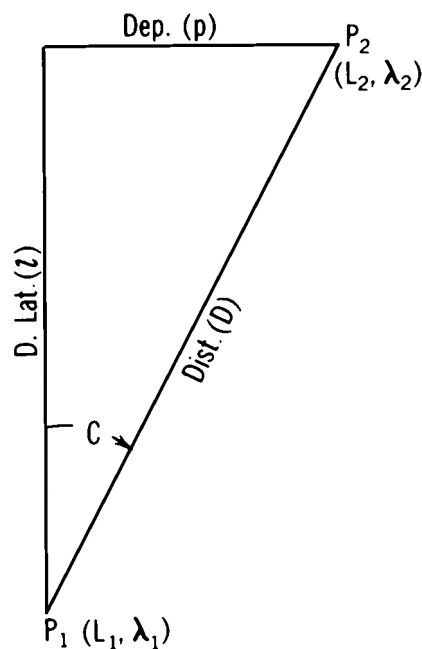

Figure B6. The plane sailing triangle.

- **Parallel sailing** consists of interconverting departure and difference of longitude. Refer to Figure 0.

$$DLo = p \sec L, \text{ and } p = DLo \cos L$$

- **Mid-latitude sailing** combines plane and parallel sailing, with certain assumptions. The mean latitude (Lm) is half of the arithmetical sum of the latitudes of two places on the same side of the equator. For places on opposite sides of the equator, the N and S portions are solved separately.

In mid-latitude sailing:

$$DLo = p \sec Lm, \text{ and } p = DLo \cos Lm$$

- **Mercator Sailing** problems are solved graphically on a Mercator chart. For mathematical Mercator solutions the formulas are:

$$\tan C = \frac{DLo}{m} \text{ or } DLo = m \tan C$$

where m is the meridional part from [Table 6](#) in the Tables Part of this volume. Following solution of the course angle by Mercator sailing, the distance is by the plane sailing formula:

$$D = 1 \sec C.$$

- **Great-circle solutions for distance and initial course angle** can be calculated from the formulas:

$$D = \cos^{-1} [(\sin L_1 \sin L_2 + \cos L_1 \cos L_2 \cos DLo)],$$

and

$$C = \tan^{-1} \left( \frac{\sin DLo}{(\cos L_1 \tan L_2) - (\sin L_1 \cos DLo)} \right)$$

where D is the great-circle distance, C is the initial great-circle course angle,  $L_1$  is the latitude of the point of departure,  $L_2$  is the latitude of the destination, and DLo is the difference of longitude of the points of departure and destination. If the name of the latitude of the destination is contrary to that of the point of departure, it is treated as a negative quantity.

- **The latitude of the vertex**,  $L_v$ , is always numerically equal to or greater than  $L_1$  or  $L_2$ . If the initial course angle C is less than  $90^\circ$ , the vertex is toward  $L_2$ , but if C is greater than  $90^\circ$ , the nearer vertex is in the opposite direction. The vertex nearer  $L_1$  has the same name as  $L_1$ .

The latitude of the vertex can be calculated from the formula:

$$L_v = \cos^{-1}(\cos L_1 \sin C)$$

The difference of longitude of the vertex and the point of departure ( $DLo_v$ ) can be calculated from the formula:

$$DLo_v = \sin^{-1} \left( \frac{\cos C}{\sin L_v} \right).$$

The distance from the point of departure to the vertex ( $D_v$ ) can be calculated from the formula:

$$D_v = \sin^{-1}(\cos L_1 \sin DLo_v).$$

- **The latitudes of points on the great-circle track** can be determined for equal DLo intervals each side of the vertex ( $DLo_{vx}$ ) using the formula:

$$L_x = \tan^{-1}(\cos DLo_{vx} \tan L_v)$$

The  $DLo_v$  and  $D_v$  of the nearer vertex are never greater than  $90^\circ$ . However, when  $L_1$  and  $L_2$  are of contrary name, the other vertex,  $180^\circ$  away, may be the better one to use in the solution for points on the great-circle track if it is nearer the mid point of the track.

The method of selecting the longitude (or  $DLo_{vx}$ ), and determining the latitude at which the great-circle crosses the selected meridian, provides shorter legs in higher latitudes and longer legs in lower latitudes. Points at desired distances or desired equal intervals of distance on the great-circle from the vertex ( $D_{vx}$ ) can be calculated using the formulas:

$$L_x = \sin^{-1} [\sin L_v \cos D_{vx}],$$

and

$$DLo_{vx} = \sin^{-1} \left( \frac{\sin D_{vx}}{\cos L_x} \right).$$

A calculator which converts rectangular to polar coordinates provides easy solutions to plane sailings. However, the user must know whether the difference of latitude corresponds to the calculator's X-coordinate or to the Y-coordinate.

### App B 7. Calculations Of Meteorology And Oceanography

- **Converting thermometer scales** between centigrade, Fahrenheit, and Kelvin scales can be done using the following formulas:

$$C^\circ = \frac{5(F^\circ - 32^\circ)}{9},$$

$$F^\circ = \frac{9}{5}C^\circ + 32^\circ, \text{ and}$$

$$K^\circ = C^\circ + 273.15^\circ.$$

- **Maximum length of sea waves** can be found by the formula:
- **Wave speed** in knots

$$W = 1.5 \sqrt{\text{fetch in nautical miles}} .$$

$$= 1.34 \sqrt{\text{wavelength in feet}}, \text{ or}$$

$$= 3.03 \text{ wave period in seconds.}$$

- **Wave height** = 0.026 S<sup>2</sup> where S is the wind speed in knots.

### UNIT CONVERSION

Use the conversion tables that appear on the following pages to convert between different systems of units. Conversions followed by an asterisk are exact relationships.

### MISCELLANEOUS DATA

#### Area

1 square inch	= 6.4516 square centimeters*
1 square foot	= 144 square inches*
	= 0.09290304 square meter*
	= 0.000022957 acre
1 square yard	= 9 square feet*
	= 0.83612736 square meter
1 square (statute) mile	= 27,878,400 square feet*
	= 640 acres*
	= 2.589988110336 square kilometers*
1 square centimeter	= 0.1550003 square inch
	= 0.00107639 square foot
1 square meter	= 10.76391 square feet
	= 1.19599005 square yards
1 square kilometer	= 247.1053815 acres
	= 0.38610216 square statute mile
	= 0.29155335 square nautical mile

#### Astronomy

1 mean solar unit	= 1.00273791 sidereal units
1 sidereal unit	= 0.99726957 mean solar units
1 microsecond	= 0.000001 second*
1 second	= 1,000,000 microseconds*
	= 0.01666667 minute
	= 0.00027778 hour
	= 0.00001157 day
1 minute	= 60 seconds*
	= 0.01666667 hour
	= 0.00069444 day
1 hour	= 3,600 seconds*
	= 60 minutes*
	= 0.04166667 day
1 mean solar day	= 24 <sup>h</sup> 03 <sup>m</sup> 56 <sup>s</sup> .55536 of mean sidereal time
	= 1 rotation of Earth with respect to Sun (mean)*
	= 1.00273791 rotations of Earth
	with respect to vernal equinox (mean)
	= 1.0027378118868 rotations of Earth
	with respect to stars (mean)
1 mean sidereal day	= 23 <sup>h</sup> 56 <sup>m</sup> 04 <sup>s</sup> .09054 of mean solar time
1 sidereal month	= 27.321661 days
	= 27 <sup>d</sup> 07 <sup>h</sup> 43 <sup>m</sup> 11 <sup>s</sup> .5
1 synodical month	= 29.530588 days
	= 29 <sup>d</sup> 12 <sup>h</sup> 44 <sup>m</sup> 02 <sup>s</sup> .8

1 tropical (ordinary) year	$= 31,556,925.975$ seconds $= 525,948.766$ minutes $= 8,765.8128$ hours $= 365^{\text{d}}.24219879 - 0^{\text{d}}.0000000614(t-1900)$ , where $t$ = the year (date) $= 365^{\text{d}}05^{\text{h}}48^{\text{m}}46^{\text{s}} (-) 0^{\text{s}}.0053(t-1900)$
1 sidereal year	$= 365^{\text{d}}.25636042 + 0.0000000011(t-1900)$ , where $t$ = the year (date) $= 365^{\text{d}}06^{\text{h}}09^{\text{m}}09^{\text{s}}.5 (+) 0^{\text{s}}.0001(t-1900)$
1 calendar year (common)	$= 31,536,000$ seconds* $= 525,600$ minutes* $= 8,760$ hours* $= 365$ days*
1 calendar year (leap)	$= 31,622,400$ seconds* $= 527,040$ minutes* $= 8,784$ hours* $= 366$ days
1 light-year	$= 9,460,000,000,000$ kilometers $= 5,880,000,000,000$ statute miles $= 5,110,000,000,000$ nautical miles $= 63,240$ astronomical units $= 0.3066$ parsecs
1 parsec	$= 30,860,000,000,000$ kilometers $= 19,170,000,000,000$ statute miles $= 16,660,000,000,000$ nautical miles $= 206,300$ astronomical units $= 3.262$ light years
1 astronomical unit	$= 149,600,000$ kilometers $= 92,960,000$ statute miles $= 80,780,000$ nautical miles $= 499^{\text{s}}.012$ light-time $=$ mean distance, Earth to Sun
Mean distance, Earth to Moon	$= 384,400$ kilometers $= 238,855$ statute miles $= 207,559$ nautical miles
Mean distance, Earth to Sun	$= 149,600,000$ kilometers $= 92,957,000$ statute miles $= 80,780,000$ nautical miles $= 1$ astronomical unit
Sun's diameter	$= 1,392,000$ kilometers $= 865,000$ statute miles $= 752,000$ nautical miles
Sun's mass	$= 1,987,000,000,000,000,000,000,000,000,000$ grams $= 2,200,000,000,000,000,000,000,000,000,000$ short tons $= 2,000,000,000,000,000,000,000,000,000,000$ long tons
Speed of Sun relative to neighboring stars	$= 19.4$ kilometers per second $= 12.1$ statute miles per second $= 10.5$ nautical miles per second
Orbital speed of Earth	$= 29.8$ kilometers per second $= 18.5$ statute miles per second $= 16.1$ nautical miles per second
Obliquity of the ecliptic	$= 23^{\circ}27'08''.26 - 0''.4684 (t-1900)$ , where $t$ = the year (date)
General precession of the equinoxes	$= 50''.2564 + 0''.000222 (t-1900)$ , per year, where $t$ = the year (date)
Precession of the equinoxes in right ascension	$= 46''.0850 + 0''.000279 (t-1900)$ , per year, where $t$ = the year (date)
Precession of the equinoxes in declination	$= 20''.0468 - 0''.000085 (t-1900)$ , per year, where $t$ = the year (date)



Magnitude ratio \_ \_ \_ \_ \_ = 2.512  
 =  $\sqrt[5]{100}$ \*

**Charts**

Nautical miles per inch \_ \_ \_ \_ \_ = reciprocal of natural scale 72,913.39  
 Statute miles per inch \_ \_ \_ \_ \_ = reciprocal of natural scale 63,360\*  
 Inches per nautical mile \_ \_ \_ \_ \_ = 72,913.39 natural scale  
 Inches per statute mile \_ \_ \_ \_ \_ = 63,360 natural scale\*  
 Natural scale \_ \_ \_ \_ \_ = 1:72,913.39 nautical miles per inch  
 = 1:63,360 statute miles per inch\*

**Earth**

Acceleration due to gravity (standard) \_ \_ \_ \_ \_ = 980.665 centimeters per second per second  
 = 32.1740 feet per second per second  
 Mass-ratio—Sun/Earth \_ \_ \_ \_ \_ = 332,958  
 Mass-ratio—Sun/(Earth & Moon) \_ \_ \_ \_ \_ = 328,912  
 Mass-ratio—Earth/Moon \_ \_ \_ \_ \_ = 81.30  
 Mean density \_ \_ \_ \_ \_ = 5.517 grams per cubic centimeter  
 Velocity of escape \_ \_ \_ \_ \_ = 6.94 statute miles per second  
 Curvature of surface \_ \_ \_ \_ \_ = 0.8 foot per nautical mile

*World Geodetic System (WGS) Ellipsoid of 1984*

Equatorial radius (a) \_ \_ \_ \_ \_ = 6,378,137 meters  
 = 3,443.918 nautical miles  
 Polar radius (b) \_ \_ \_ \_ \_ = 6,356,752.314 meters  
 = 3432.372 nautical miles  
 Mean radius (2a + b)/3 \_ \_ \_ \_ \_ = 6,371,008.770 meters  
 = 3440.069 nautical miles  
 Flattening or ellipticity (f = 1 - b/a) \_ \_ \_ \_ \_ = 1/298.257223563  
 = 0.003352811  
 Eccentricity (e = (2f - f<sup>2</sup>)<sup>1/2</sup>) \_ \_ \_ \_ \_ = 0.081819191  
 Eccentricity squared (e<sup>2</sup>) \_ \_ \_ \_ \_ = 0.006694380

**Length**

1 inch \_ \_ \_ \_ \_ = 25.4 millimeters\*  
 = 2.54 centimeters\*  
 1 foot (U.S.) \_ \_ \_ \_ \_ = 12 inches\*  
 = 1 British foot  
 =  $\frac{1}{3}$  yard\*  
 = 0.3048 meter\*  
 =  $\frac{1}{6}$  fathom\*  
 1 foot (U.S. Survey) \_ \_ \_ \_ \_ = 0.30480061 meter  
 1 yard \_ \_ \_ \_ \_ = 36 inches\*  
 = 3 feet\*  
 = 0.9144 meter\*  
 1 fathom \_ \_ \_ \_ \_ = 6 feet\*  
 = 2 yards\*  
 = 1.8288 meters\*  
 1 cable \_ \_ \_ \_ \_ = 720 feet\*  
 = 240 yards\*  
 = 219.4560 meters\*  
 1 cable (British) \_ \_ \_ \_ \_ = 0.1 nautical mile  
 1 statute mile \_ \_ \_ \_ \_ = 5,280 feet\*  
 = 1,760 yards\*  
 = 1,609.344 meters\*  
 = 1.609344 kilometers\*  
 = 0.86897624 nautical mile  
 1 nautical mile \_ \_ \_ \_ \_ = 6,076.11548556 feet  
 = 2,025.37182852 yards  
 = 1,852 meters\*  
 = 1.852 kilometers\*  
 = 1.150779448 statute miles

1 meter	= 100 centimeters*
	= 39.370079 inches
	= 3.28083990 feet
	= 1.09361330 yards
	= 0.54680665 fathom
	= 0.00062137 statute mile
	= 0.00053996 nautical mile
1 kilometer	= 3,280.83990 feet
	= 1,093.61330 yards
	= 1,000 meters*
	= 0.62137119 statute mile
	= 0.53995680 nautical mile

**Mass**

1 ounce	= 437.5 grains*
	= 28.349523125 grams*
	= 0.0625 pound*
	= 0.028349523125 kilogram*
1 pound	= 7,000 grains*
	= 16 ounces*
	= 0.45359237 kilogram*
1 short ton	= 2,000 pounds*
	= 907.18474 kilograms*
	= 0.90718474 metric ton*
	= 0.8928571 long ton
1 long ton	= 2,240 pounds*
	= 1,016.0469088 kilograms*
	= 1.12 short tons*
	= 1.0160469088 metric tons*
1 kilogram	= 2.204623 pounds
	= 0.00110231 short ton
	= 0.0009842065 long ton
1 metric ton	= 2,204.623 pounds
	= 1,000 kilograms*
	= 1.102311 short tons
	= 0.9842065 long ton

**Mathematics**

$\pi$	= 3.1415926535897932384626433832795028841971
$\pi^2$	= 9.8696044011
$\sqrt{\pi}$	= 1.7724538509
Base of Naperian logarithms (e)	= 2.718281828459
Modulus of common logarithms ( $\log_{10}e$ )	= 0.4342944819032518
1 radian	= 206,264."80625
	= 3,437'.7467707849
	= 57°.2957795131
	= 57°17'44".80625
1 circle	= 1,296,000"*
	= 21,600'*
	= 360°*
	= $2\pi$ radians*
180°	= $\pi$ radians*
1°	= 3600"*
	= 60'*
	= 0.0174532925199432957666 radian
1'	= 60"*
	= 0.000290888208665721596 radian
1"	= 0.000004848136811095359933 radian
Sine of 1'	= 0.00029088820456342460
Sine of 1"	= 0.00000484813681107637

**Meteorology**

Atmosphere (dry air)	
Nitrogen	= 78.08%
Oxygen	= 20.95%
Argon	= 0.93%
Carbon dioxide	= 0.03%
Neon	= 0.0018%
Helium	= 0.000524%
Krypton	= 0.0001%
Hydrogen	= 0.00005%
Xenon	= 0.0000087%
Ozone	= 0 to 0.000007% (increasing with altitude)
Radon	= 0.000000000000000006% (decreasing with altitude)
Standard atmospheric pressure at sea level	= 1,013.250 dynes per square centimeter
	= 1,033.227 grams per square centimeter
	= 1,033.227 centimeters of water
	= 1,013.250 hectopascals (millibars)*
	= 760 millimeters of mercury
	= 76 centimeters of mercury
	= 33.8985 feet of water
	= 29.92126 inches of mercury
	= 14.6960 pounds per square inch
	= 1.033227 kilograms per square centimeter
	= 1.013250 bars*
Absolute zero	= (-)273.16°C
	= (-)459.69°F

**Pressure**

1 dyne per square centimeter	= 0.001 hectopascal (millibar)*
	= 0.000001 bar*
1 gram per square centimeter	= 1 centimeter of water
	= 0.980665 hectopascal (millibar)*
	= 0.07355592 centimeter of mercury
	= 0.0289590 inch of mercury
	= 0.0142233 pound per square inch
	= 0.001 kilogram per square centimeter*
	= 0.000967841 atmosphere
1 hectopascal (millibar)	= 1,000 dynes per square centimeter*
	= 1.01971621 grams per square centimeter
	= 0.7500617 millimeter of mercury
	= 0.03345526 foot of water
	= 0.02952998 inch of mercury
	= 0.01450377 pound per square inch
	= 0.001 bar*
	= 0.00098692 atmosphere
1 millimeter of mercury	= 1.35951 grams per square centimeter
	= 1.3332237 hectopascals (millibars)
	= 0.1 centimeter of mercury*
	= 0.04460334 foot of water
	= 0.039370079 inch of mercury
	= 0.01933677 pound per square inch
	= 0.001315790 atmosphere
1 centimeter of mercury	= 10 millimeters of mercury*
1 inch of mercury	= 34.53155 grams per square centimeter
	= 33.86389 hectopascals (millibars)
	= 25.4 millimeters of mercury*
	= 1.132925 feet of water
	= 0.4911541 pound per square inch
	= 0.03342106 atmosphere
1 centimeter of water	= 1 gram per square centimeter
	= 0.001 kilogram per square centimeter
1 foot of water	= 30.48000 grams per square centimeter
	= 29.89067 hectopascals (millibars)
	= 2.241985 centimeters of mercury
	= 0.882671 inch of mercury
	= 0.4335275 pound per square inch
	= 0.02949980 atmosphere

1 pound per square inch	= 68,947.57 dynes per square centimeter
	= 70.30696 grams per square centimeter
	= 70.30696 centimeters of water
	= 68.94757 hectopascals (millibars)
	= 51.71493 millimeters of mercury
	= 5.171493 centimeters of mercury
	= 2.306659 feet of water
	= 2.036021 inches of mercury
	= 0.07030696 kilogram per square centimeter
	= 0.06894757 bar
	= 0.06804596 atmosphere
1 kilogram per square centimeter	= 1,000 grams per square centimeter*
	= 1,000 centimeters of water
1 bar	= 1,000,000 dynes per square centimeter*
	= 1,000 hectopascals (millibars)*

**Speed**

1 foot per minute	= 0.01666667 foot per second
	= 0.00508 meter per second*
1 yard per minute	= 3 feet per minute*
	= 0.05 foot per second*
	= 0.03409091 statute mile per hour
	= 0.02962419 knot
	= 0.01524 meter per second*
1 foot per second	= 60 feet per minute*
	= 20 yards per minute*
	= 1.09728 kilometers per hour*
	= 0.68181818 statute mile per hour
	= 0.59248380 knot
	= 0.3048 meter per second*
1 statute mile per hour	= 88 feet per minute*
	= 29.33333333 yards per minute
	= 1.609344 kilometers per hour*
	= 1.46666667 feet per second
	= 0.86897624 knot
	= 0.44704 meter per second*
1 knot	= 101.26859143 feet per minute
	= 33.75619714 yards per minute
	= 1.852 kilometers per hour*
	= 1.68780986 feet per second
	= 1.15077945 statute miles per hour
	= 0.51444444 meter per second
1 kilometer per hour	= 0.62137119 statute mile per hour
	= 0.53995680 knot
1 meter per second	= 196.85039340 feet per minute
	= 65.6167978 yards per minute
	= 3.6 kilometers per hour*
	= 3.28083990 feet per second
	= 2.23693632 statute miles per hour
	= 1.94384449 knots
Light in vacuum	= 299,792.5 kilometers per second
	= 186,282 statute miles per second
	= 161,875 nautical miles per second
	= 983.570 feet per microsecond
Light in air	= 299,708 kilometers per second
	= 186,230 statute miles per second
	= 161,829 nautical miles per second
	= 983.294 feet per microsecond
Sound in dry air at 59°F or 15°C and standard sea level pressure	= 1,116.45 feet per second
	= 761.22 statute miles per hour
	= 661.48 knots
	= 340.29 meters per second

Sound in 3.485 percent saltwater at 60°F \_ \_ \_ = 4,945.37 feet per second  
 = 3,371.85 statute miles per hour  
 = 2,930.05 knots  
 = 1,507.35 meters per second

**Volume**

1 cubic inch \_ \_ \_ \_ \_ = 16.387064 cubic centimeters\*  
 = 0.016387064 liter\*  
 = 0.004329004 gallon

1 cubic foot \_ \_ \_ \_ \_ = 1,728 cubic inches\*  
 = 28.316846592 liters\*  
 = 7.480519 U.S. gallons  
 = 6.228822 imperial (British) gallons  
 = 0.028316846592 cubic meter\*

1 cubic yard \_ \_ \_ \_ \_ = 46,656 cubic inches\*  
 = 764.554857984 liters\*  
 = 201.974026 U.S. gallons  
 = 168.1782 imperial (British) gallons  
 = 27 cubic feet\*  
 = 0.764554857984 cubic meter\*

1 milliliter \_ \_ \_ \_ \_ = 0.06102374 cubic inch  
 = 0.0002641721 U.S. gallon  
 = 0.00021997 imperial (British) gallon

1 cubic meter \_ \_ \_ \_ \_ = 264.172035 U.S. gallons  
 = 219.96878 imperial (British) gallons  
 = 35.31467 cubic feet  
 = 1.307951 cubic yards

1 quart (U.S.) \_ \_ \_ \_ \_ = 57.75 cubic inches\*  
 = 32 fluid ounces\*  
 = 2 pints\*  
 = 0.9463529 liter  
 = 0.25 gallon\*

1 gallon (U.S.) \_ \_ \_ \_ \_ = 3,785.412 milliliters  
 = 231 cubic inches\*  
 = 0.1336806 cubic foot  
 = 4 quarts\*  
 = 3.785412 liters  
 = 0.8326725 imperial (British) gallon

1 liter \_ \_ \_ \_ \_ = 1,000 milliliters  
 = 61.02374 cubic inches  
 = 1.056688 quarts  
 = 0.2641721 gallon

1 register ton \_ \_ \_ \_ \_ = 100 cubic feet\*  
 = 2.8316846592 cubic meters\*

1 measurement ton \_ \_ \_ \_ \_ = 40 cubic feet\*  
 = 1 freight ton\*

1 freight ton \_ \_ \_ \_ \_ = 40 cubic feet\*  
 = 1 measurement ton\*

**Volume-Mass**

1 cubic foot of seawater \_ \_ \_ \_ \_ = 64 pounds  
 1 cubic foot of freshwater \_ \_ \_ \_ \_ = 62.428 pounds at temperature of maximum density (4°C = 39°.2F)  
 1 cubic foot of ice \_ \_ \_ \_ \_ = 56 pounds  
 1 displacement ton \_ \_ \_ \_ \_ = 35 cubic feet of seawater\*  
 = 1 long ton

**Prefixes to Form Decimal Multiples and Sub-Multiples  
of International System of Units (SI)**

Multiplying factor		Prefix	Symbol
1 000 000 000 000 = 10 <sup>12</sup>		tera	T
1 000 000 000 = 10 <sup>9</sup>		giga	G
1 000 000 = 10 <sup>6</sup>		mega	M
1 000 = 10 <sup>3</sup>		kilo	k
100 = 10 <sup>2</sup>		hecto	h
10 = 10 <sup>1</sup>		deka	da
0.1 = 10 <sup>-1</sup>		deci	d
0.01 = 10 <sup>-2</sup>		centi	c
0.001 = 10 <sup>-3</sup>		milli	m
0.000 001 = 10 <sup>-6</sup>		micro	
0.000 000 001 = 10 <sup>-9</sup>		nano	n
0.000 000 000 001 = 10 <sup>-12</sup>		pico	p
0.000 000 000 000 001 = 10 <sup>-15</sup>		femto	f
0.000 000 000 000 000 001 = 10 <sup>-18</sup>		atto	a

**NGA MARITIME SAFETY INFORMATION NAUTICAL CALCULATORS**

NGA's **Maritime Safety Office website** offers a variety of online Nautical Calculators for public use. These calculators solve many of the equations and conversions typically associated with marine navigation. See the link provided below.



*Link to NGA Nautical Calculators.*

[https://msi.nga.mil/NGAPortal/MSI.portal?\\_nfpb=true&\\_st=&\\_pageLabel=msi\\_portal\\_page\\_145](https://msi.nga.mil/NGAPortal/MSI.portal?_nfpb=true&_st=&_pageLabel=msi_portal_page_145)

**List of NGA Maritime Safety information Nautical Calculators** <https://msi.nga.mil>

<b>Celestial Navigation Calculators</b>
Compass Error from Amplitudes Observed on the Visible Horizon
Altitude Correction for Air Temperature
Table of Offsets
Latitude and Longitude Factors
Altitude Corrections for Atmospheric Pressure
Altitude Factors & Change of Altitude



**List of NGA Maritime Safety information Nautical Calculators** <https://msi.nga.mil>

Pub 229
Compass Error from Amplitudes observed on the Celestial Horizon
<b>Conversion Calculators</b>
Chart Scales and Conversions for Nautical and Statute Miles
Conversions for Meters, Feet and Fathoms
<b>Distance Calculators</b>
Length of a Degree of Latitude and Longitude
Speed for Measured Mile and Speed, Time and Distance
Distance of an Object by Two Bearings
Distance of the Horizon
Distance by Vertical Angle Measured Between Sea Horizon and Top of Object Beyond Sea Horizon
Traverse Table
Geographic Range
Distance by Vertical Angle Measured Between Waterline at Object and Top of Object
Dip of Sea Short of the Horizon
Distance by Vertical Angle Measured Between Waterline at Object and Sea Horizon Beyond Object
Meridional Parts
<b>Log and Trig Calculators</b>
Logarithmic and Trigonometric Functions
<b>Sailings Calculators</b>
Great Circle Sailing
Mercator NGA Sailing
<b>Time Zones Calculators</b>
Time Zones, Zone Descriptions and Suffixes
<b>Weather Data Calculators</b>
Direction and Speed of True Wind
Correction of Barometer Reading for Height Above Sea Level
Correction of Barometer Reading for Gravity
Temperature Conversions
Relative Humidity and Dew Point
Corrections of Barometer Reading for Temperature
Barometer Measurement Conversions



# APPENDIX C

## SATELLITE NAVIGATION

### GPS SIGNAL CODING

#### App C 001. The GPS L1 Band

The GPS L1 band (1575.42 MHz) has turned out to be the most important band for navigation purposes. Indeed most of the applications in the world nowadays are based on the signals transmitted at this frequency. Three signals are transmitted at the moment by GPS in L1: C/A Code, P(Y) Code and M-Code. In the future, an additional new civil signal, known as L1C, will also be transmitted. We describe all of them in the next lines:

- The Coarse/Acquisition (C/A) code signal was primarily thought of for acquisition of the P (or Y) code and has become nowadays the most important signal for mass market applications.
- The P Code is the precision signal and is coded by the precision code. Moreover the Y-Code is used in place of the P-code whenever the Anti-Spoofing (A/S) mode of operation is activated as described in the GPS ICDs 203, 224 and 225.
- The modernized military signal (M-Code) is designed exclusively for military use and is intended to eventually replace the P(Y) code [E. D. Kaplan and C. Hegarty, 2006]. The M-Code provides better jamming resistance than the P(Y) signal, primarily through enabling transmission at much higher power

without interference with C/A code or P(Y) code receivers [B.C. Barker et al., 2000]. Moreover, the M-Code provides more robust signal acquisition than is achieved today, while offering better security in terms of exclusivity, authentication, and confidentiality, along with streamlined key distribution. In other aspects, the M-Code signal provides much better performance than the P(Y) Code and more flexibility.

- The L1 Civil signal (L1C), defined in the [GPS ICD-800], consists of two main components; one denoted  $L1C_P$  to represent the pilot signal, consisting of a time-multiplexing of Binary Offset Carrier BOC(1,1) and BOC(6,1), thus without any data message, and  $L1C_D$  with a pure BOC(1,1), for the data channel. This is spread by a ranging code and modulated by a data message. The pilot channel  $L1C_P$  is also modulated by an SV unique overlay secondary code,  $L1C_O$ .

For more details on the code generation refer to the [GPS ICD 200] and [GPS ICD-800]. Finally, the technical characteristics of the existing and planned GPS signals in the L1 band are summarized in the following Table 001.

GNSS System	GPS	GPS		GPS	GPS
Service Name	C/A	L1C		P(Y) Code	M-Code
Center Frequency	1575.42 MHz	1575.42 MHz		1575.42 MHz	1575.42 MHz
Frequency Band	L1	L1		L1	L1
Access Technique	CDMA	CDMA		CDMA	CDMA
Signal Component	Data	Data	Pilot	Data	N/A
Modulation	BPSK(1)	TMBOC(6,1,1/11)		BPSK(10)	BOC <sub>sin</sub> (10,5)
Sub-carrier Frequency [MHz]	-	1.023	1.023 & 6.138	-	10.23
Code Frequency	1.023 MHz	1.023 MHz		10.23 MHz	5.115 MHz
Primary PRN Code Length	1023	10230		$6.19 \times 10^{12}$	N/A
Code Family	Gold Codes	Weil Codes		Combo and short cycling of M-sequences	N/A

Table 001. GPS L1 signal technical characteristics.

GNSS System	GPS	GPS		GPS	GPS
Secondary PRN Code Length	-	-	1800	-	N/A
Data Rate	50 bps/ 50 sps	50 bps/ 100 sps	-	50 bps/ 50 sps	N/A
Minimum Received Power [dBW]	-158.5	-157		-161.5	N/A
Elevation	5°	5°		5°	5°

Table 001. GPS L1 signal technical characteristics.

Of all the signals shown in Table 001, the C/A Code is the best known as most of the receivers that have been built un-til today are based on it. The C/A Code was open from the very beginning to all users, although until May 1, 2000, an artificial degradation was introduced by means of the **Select Availability (SA)** mechanism which added an intentional distortion to degrade the positioning quality of the signal to non-desired users. As we have already mentioned, the C/A Code was thought to be an aid for the P(Y) Code (to realize a Coarse Acquisition). The M-Code is the last military sig-nal that has been introduced in GPS.

For a long time different signal structures for the M-Code were under consideration [J.W. Betz, 2001] being the Manchester code signals - **Binary Phase Shift Keying (BPSK)** and the **binary offset carrier (BOC)** signals the two favored candidates. Both solutions result from the modulation of a non-return to zero (NRZ) pseudo random noise spreading code by a square-wave sub-carrier. While the Manchester code has a spreading code of rate equal to that of the square-wave, the BOC signal does not necessarily have to be so, being the only constraint that the rate of the spreading code must be less than the sub-carrier frequency.

The interesting aspect about these signals is that, like the conventional sub-carrier modulation, the waveform presents a zero at the carrier frequency due to the square-wave sub-carrier. In fact, their split-power spectra clearly facilitate the compatibility of the GPS military M-Code signal with the existing C/A Code and P(Y) Code. See Figure 001 - *Spectra of GPS signals in L1*.

We can clearly recognize that GPS L1C concentrates more power at higher frequencies - due to BOC(6,1) - in the pilot channel than in the data channel.

Finally, it is important to note that for all the figures next the commonly used expressions for bandwidths in MHz must be understood as multiplied by the factor 1.023. Thus BPSK(10) refers in reality to a BPSK signal with a chip rate of 10.23 MHz. This remains valid for all the bandwidths in this thesis, unless different stated otherwise

## App C 002. The GPS L2 Band

GPS is transmitting in the L2 band (1227.60 MHz) a modernized civil signal known as L2C together with the P(Y) Code and the M-Code. The P(Y) Code and M-Code were already described shortly in the previous chapter and the properties and parameters are thus similar to those in the L1 band. In addition, for Block IIR-M, IIF, and subsequent blocks of SVs, two additional PRN ranging codes will be transmitted. They are the L2 Civil Moderate (L2 CM) code and the L2 Civil Long (L2 CL) code. These two signals are time multiplexed so that the resulting chipping rate is double as high as that of each individual signal. We further describe them in the next lines more in detail:

- L2 CM Code is transmitted in the IIR-M, IIF, and subsequent blocks. The PRN L2 CM Code for SV number  $i$  is a ranging code,  $CM_i(t)$ , which is 20 milliseconds in length at a chipping rate of 511.5 Kbps. The epochs of the L2 CM Code are synchronized with the X1 epochs of the P-code. The  $CM_i(t)$  sequence is a linear pattern which is short cycled every count period of 10,230 chips by resetting with a particular initial state. Furthermore, for Block IIR-M, the navigation data is also Modulo-2 added to the L2 CM Code. It is interesting to note that the navigation data can be used in one of two different data rates selectable by ground command: 1) D(t) with a data rate of 50 bps, or 2) D(t) with a symbol rate of 50 symbols per second (sps) which is obtained by encoding D(t) with a data rate of 25 bps coded in a rate 1/2 convolutional code. Finally, the resultant bit-train is combined with the L2 CL Code using time-division multiplexing.
- L2 CL Code is transmitted in the IIR-M, IIF, and subsequent blocks. The PRN L2 CL Code for SV number  $i$  is a ranging code,  $CL_i(t)$ , which is 1.5 seconds in length at a chipping rate of 511.5 Kbps. The epochs of the L2 CL Code are synchronized with the X1 epochs of the P Code. The  $CL_i(t)$  sequence is a linear pattern which is generated using the same code generator polynomial as of  $CM_i(t)$ . However, the  $CM_i(t)$  sequence is short cycled by resetting with an initial state every count period of

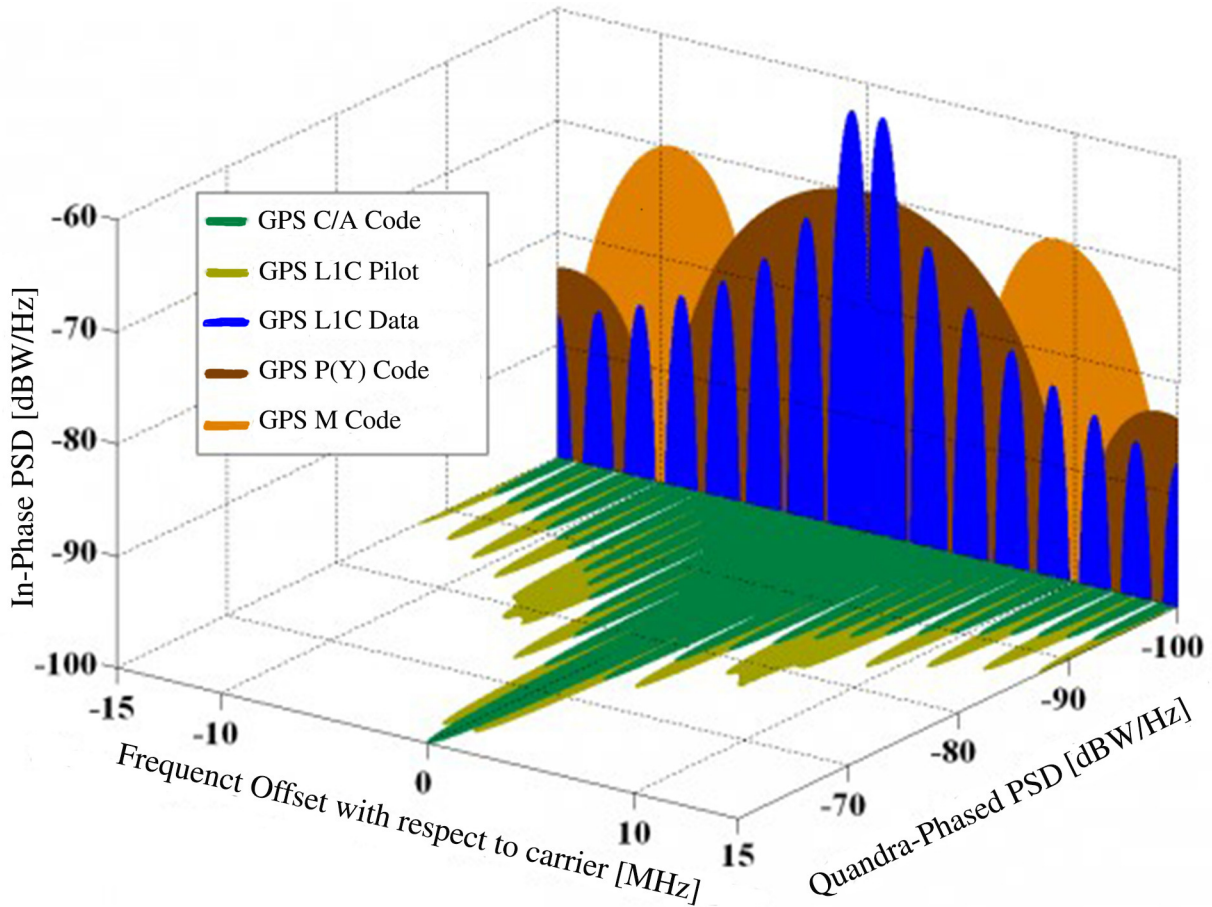

Figure 001. Spectra of GPS signals in L1. Image courtesy of Dr. Jose Angel Avila Rodriguez.

767,250 chips.

Finally, it is important to note that the GPS L2 band will have a transition period from the C/A Code to L2C and mixed configurations could occur. Figure 002a shows the baseband L2 signal generation scheme. As we can recog-

nize, although the chipping rate of the L2 CM and L2 CL signals is of 511.5 Kbps individually, after the time multiplexing the composite signal results in a stream of 1.023 MHz.

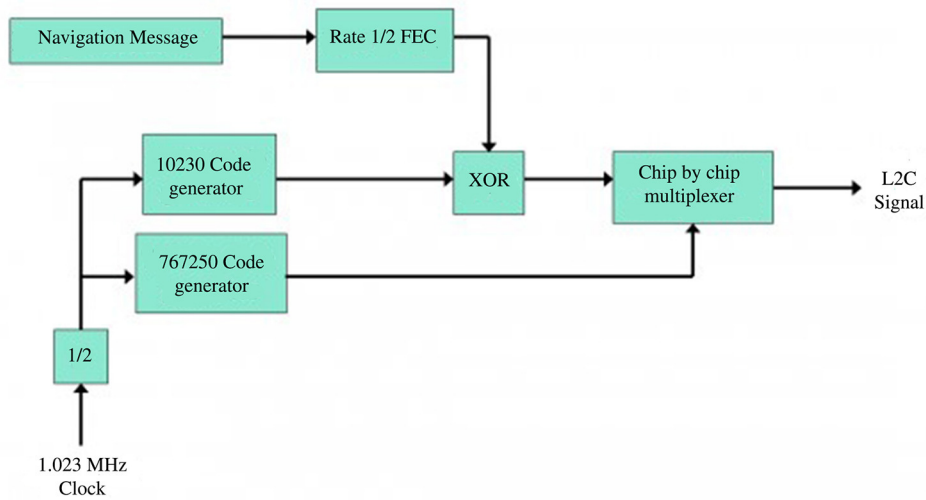

Figure 002a. Modulation scheme for the GPS L2 signals. Image courtesy of Dr. Jose Angel Avila Rodriguez.

The technical characteristics of the GPS L2 signals are summarized in Table 002a and the spectra of the different signals (L2C, P(Y) Code, and M-Code) are given in Figure 002b.

GNSS System	GPS	GPS	GPS	GPS
Service Name	L2 CM	L2 CL	P(Y) Code	M-Code
Center Frequency	1227.60 MHz	1227.60 MHz	1227.60 MHz	1227.60 MHz
Frequency Band	L2	L2	L2	L2
Access Technique	CDMA	CDMA	CDMA	CDMA
Spreading Modulation	BPSK(1) result of multiplexing 2 streams at 511.5 kHz		BPSK (10)	$\text{BOC}_{\text{sin}}(10,5)$
Sub-carrier Frequency [MHz]	-	-	-	10.23
Code Frequency	511.5 kHz	511.5 kHz	10.23 MHz	5.115 MHz
Signal Component	Data	Pilot	Data	N/A
Primary PRN Code Length	10,230 (20 ms)	767,250 (1.5 seconds)	$6.19 \times 10^{12}$	N/A
Code Family	M-sequence from a maximal polynomial of degree 27		Combo and short cycling of M-sequences	N/A
Secondary PRN Code Length	-	-	-	N/A
Data Rate	IIF 50 bps / 50 sps IIR-M Also 25 bps 50 sps with FEC	-	50 bps / 50 sps	N/A
Minimum Received Power [dBW]	II/IIA/IIR -164.5 dBW IIR-M -161.5 dBW IIF -161.5 dBW		II/IIA/IIR -164.5 dBW IIR-M -161.4 dBW IIF -160.0 dBW	N/A
Elevation	5°		5°	5°

Table 002a GPS L2 signal technical characteristics.

### App C 003. The GPS L5 Band

The GPS L5 (1176.45 MHz) signal will be transmitted for the first time on board IIF satellites. The GPS carriers of the L5 band are modulated by two bit trains in phase quadrature: the L5 data channel and the L5 pilot channel. Moreover, two PRN ranging codes are transmitted on L5: the in-phase code (denoted as the I5-code) and the quadrature code (denoted as the Q5-code). The PRN L5-codes for SV number  $i$  are independent, but time synchronized ranging codes,  $X_I^i(t)$  and  $X_Q^i(t)$ , of 1

millisecond in length at a chipping rate of 10.23 Mbps [GPS ICD-705]. For each code, the 1-millisecond sequences are the modulo-2 sum of two sub-sequences referred to as XA and XBi with lengths of 8,190 chips and 8,191 chips respectively, which restart to generate the 10,230 chip code. The XBi sequence is selectively delayed, thereby allowing the basic code generation technique to produce the different satellite codes.

See Figure 003a for the modulation scheme for the GPS L5 signals. See Figure 003b for the spectra of the GPS signals in L5. For more detail on L5, refer to (E.D. Kaplan and C. Hegarty, 2006). See Table 003 for the technical characteristics of the GPS signal in L5.



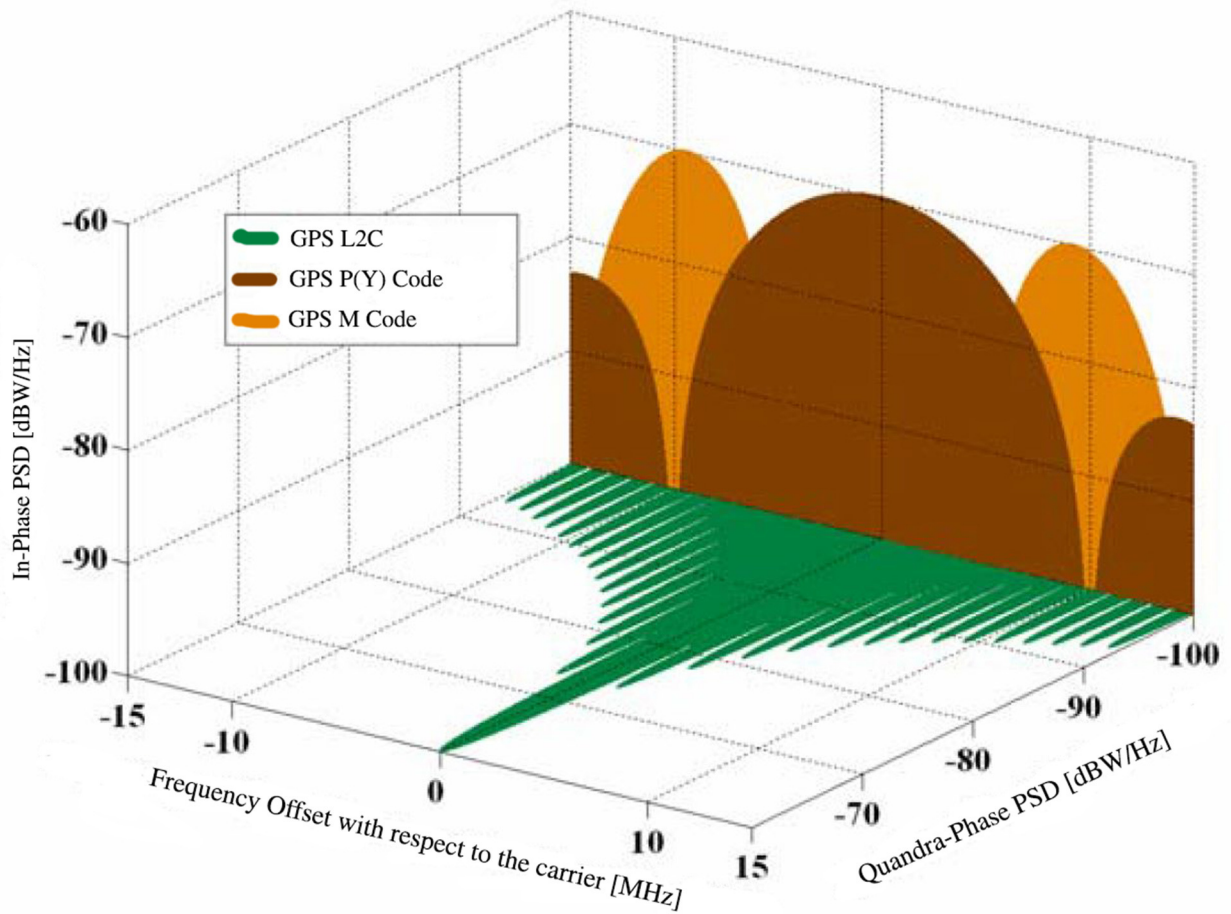

Figure 002b. Spectra of the GPS signals in L2. Image courtesy of Dr. Jose Angel Avila Rodriguez.

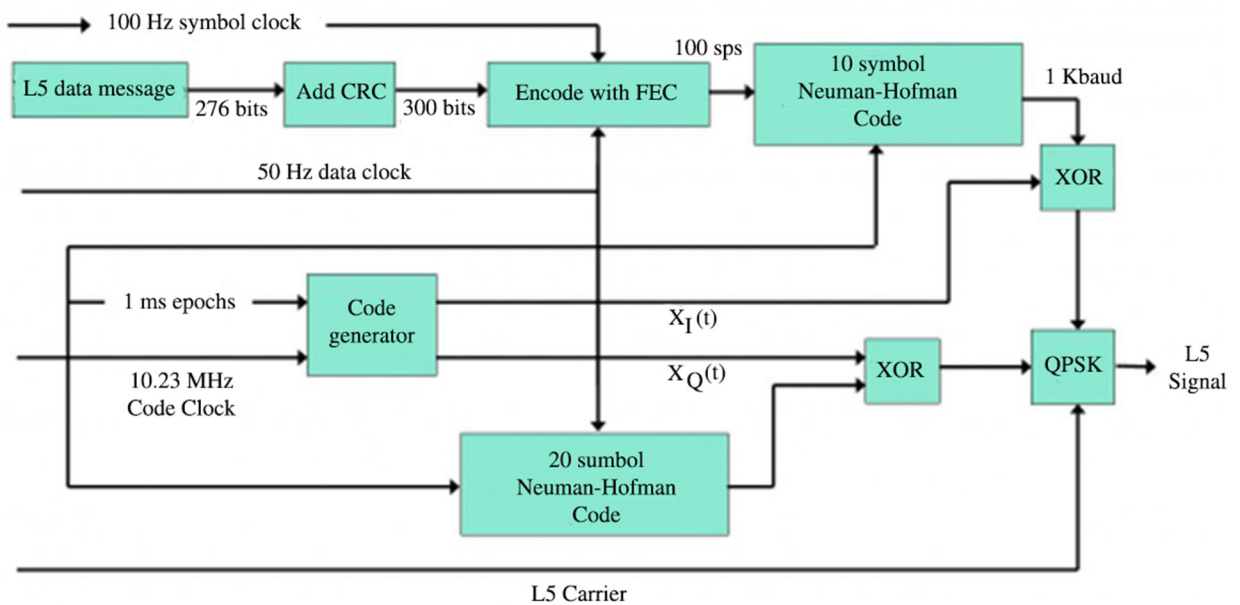

Figure 003a. Modulation scheme for the GPS L5 signals. Image courtesy of Dr. Jose Angel Avila Rodriguez.

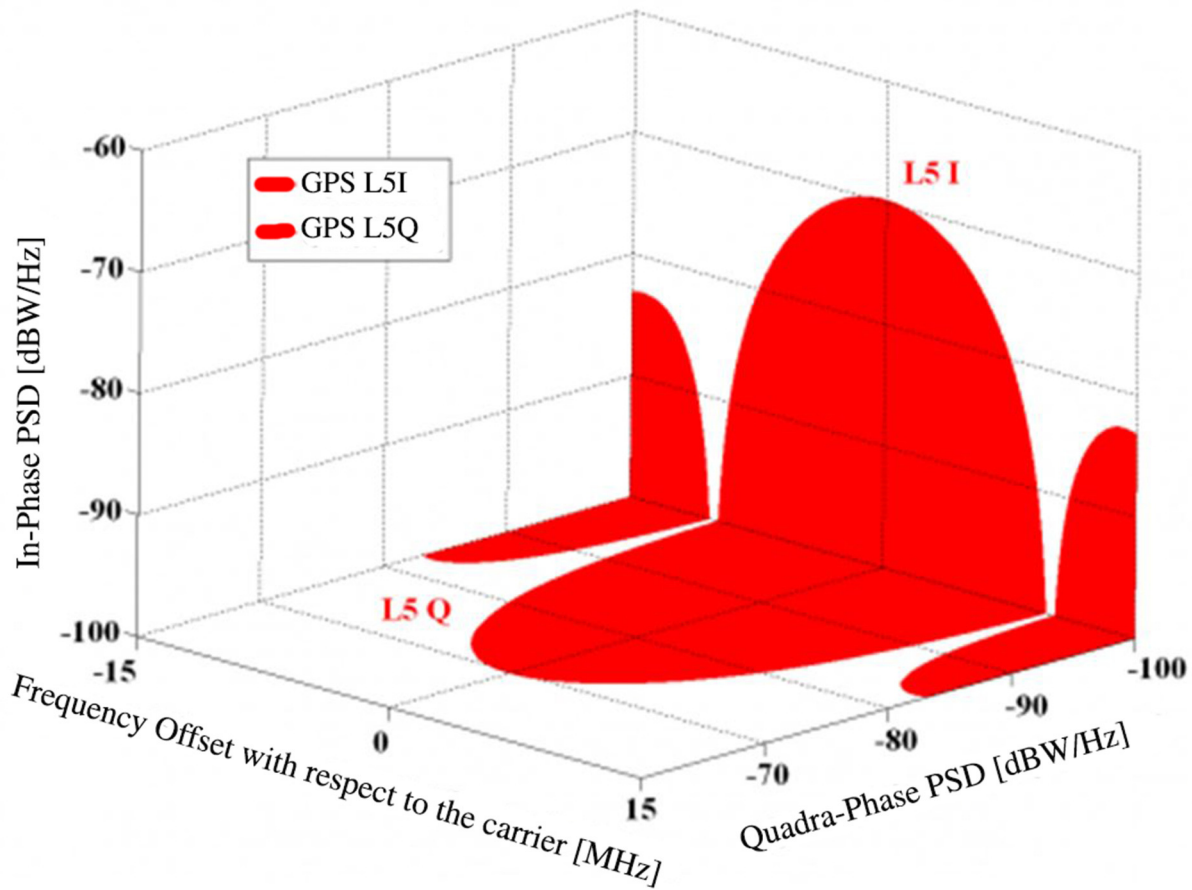

Figure 003b. Spectra of the GPS signals in L5. Image courtesy of Dr. Jose Angel Avila Rodriguez.

GNSS System	GPS	GPS
Service Name	L5I	L5Q
Center Frequency	1176.45 MHz	1176.45 MHz
Frequency Band	L5	L5
Access Technique	CDMA	CDMA
Spreading modulation	BPSK(10)	BPSK(10)
Sub-carrier Frequency	-	-
Code Frequency	10.23 MHz	10.23 MHz
Signal Component	Data	Pilot
Primary PRN Code Length	10230	10230
Code Family	Combination and short-cycling of M-sequences	
Secondary PRN Code Length	10	20

Table 003 GPS L5 signal technical characteristics.

GNSS System	GPS	GPS
Data Rate	50 bps/ 100sps	-
Minimum Received Power [dBW]	-157.9 dBW	-157.9 dBW
Elevation	5°	5°

Table 003 GPS L5 signal technical characteristics.

### THE GALILEO SIGNAL PLAN

#### App C 004. Galileo E1 Open Service Band

The E1 Open Service (OS) modulation receives the name of CBOC (Composite Binary Offset Carrier) and is a particular implementation of MBOC (Multiplexed BOC) [J.-A. Avila-Rodriguez et al., 2007]. MBOC(6,1,1/11) is the result of multiplexing a wide band signal - BOC(6,1) - with a narrow band signal - BOC(1,1) - in such a way that 1/11 of the power is allocated, in average, to the high frequency component. This signal was the last one to be defined.

The normalized (unit power) power spectral density, specified without the effect of band-limiting filters and payload imperfections, is given by

$$G_{MBOC(6,1,1/11)}(f) = \frac{10}{11}G_{BOC(1,1)}(f) + \frac{1}{11}G_{BOC(6,1)}(f) .$$

As in [Galileo SIS ICD, 2010], the generic view of the E1 Open Service signal generation can be depicted as follows [J.-A. Avila-Rodriguez et al., 2007] in Figure 004a - Modulation Scheme for Galileo E1 OS Signals:

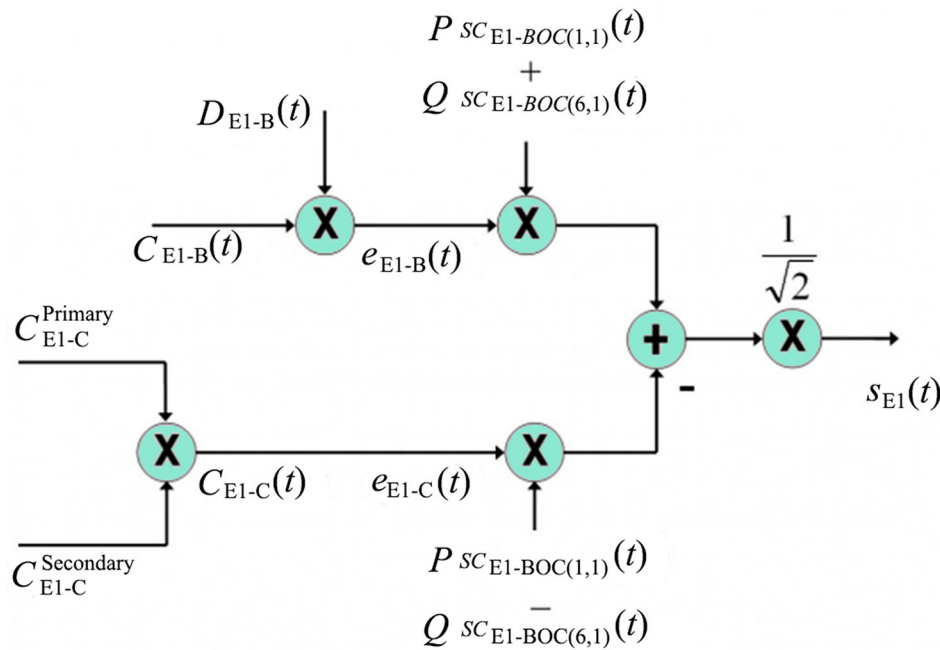

Figure 004a. Modulation scheme for Galileo E1 OS signals. Image courtesy of Dr. Jose Angel Avila Rodriguez.

The whole transmitted Galileo E1 signal consists of the multiplexing of the three following components:

- The E1 Open Service Data channel  $e_{E1-B}(t)$  is generated from the I/NAV navigation data stream  $D_{E1-B}(t)$  and the ranging code  $C_{E1-B}(t)$ , which are then modulated with the sub-carriers

$SC_{E1-BOC(1,1)}(t)$  and  $SC_{E1-BOC(6,1)}(t)$  of BOC(1,1) and BOC(6,1) respectively.

- The E1 Open Service Pilot channel  $e_{E1-C}(t)$  is generated from the ranging code  $C_{E1-C}(t)$ , including its secondary code, which is then modulated with the sub-carriers  $SC_{E1-BOC(1,1)}(t)$

and  $SC_{E1-BOC(6,1)}(t)$  in anti-phase.

- The E1 PRS channel, also denoted as E1-A, which results from the modulo-two addition (respectively product if we consider the physical bipolar representation of the signal) of the PRS data stream  $D_{PRS}(t)$ ,

the PRS sequence  $C_{PRS}(t)$  and the sub-carriers  $SC_{PRS}(t)$ . This sub-carrier consists of a BOC(15,2.5) in cosine phasing.

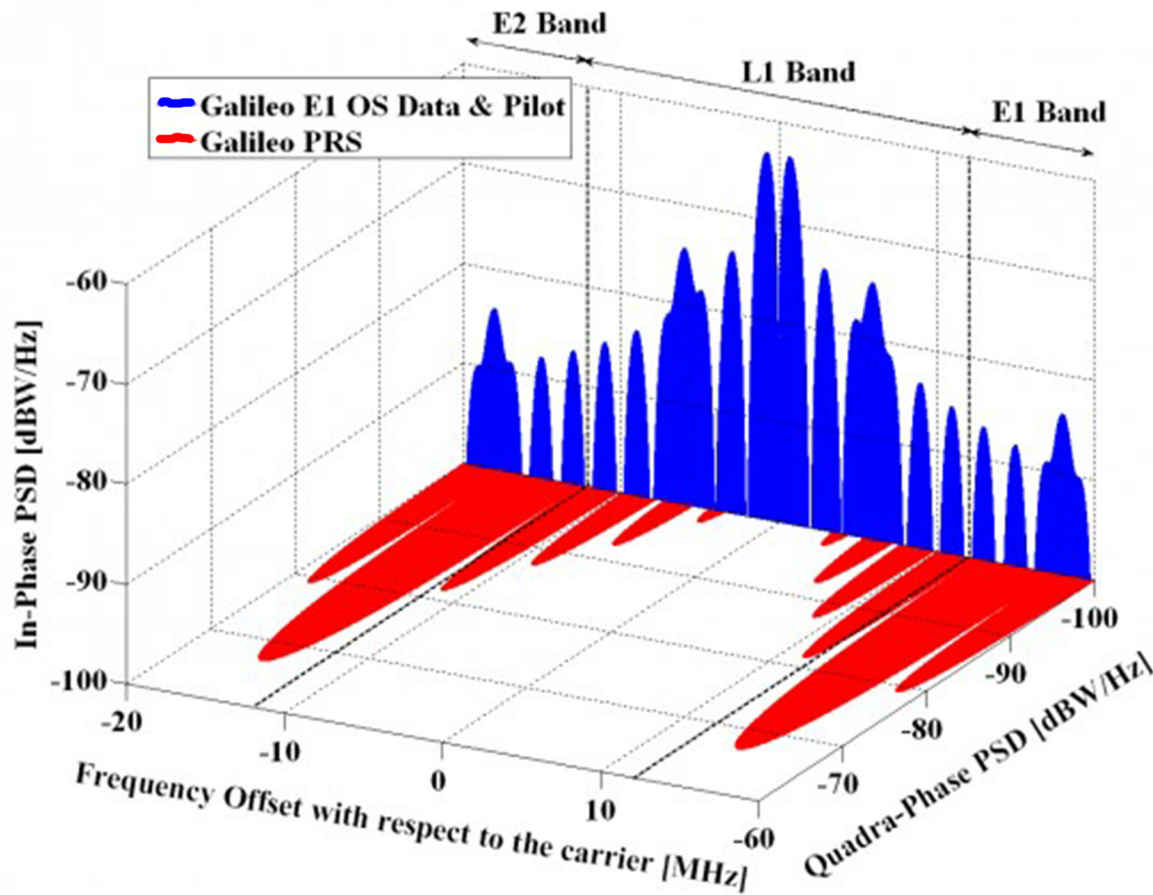

Figure 004b. Spectra of Galileo signals in E1. Image courtesy of Dr. Jose Angel Avila Rodriguez.

See for the Spectra of Galileo Signals in E1 (see Figure 004b) and for the Spectra of both GPS and Galileo Signals in L1 (see Figure 004c).

It is important to recall that for a long time the actual E1 band received the name of L1 band in analogy with GPS and it was not until the publication of the [Galileo SIS ICD, 2008] that L1 changed to the current E1.

The E1 Open Service (OS) codes are, as well as the E6 CS codes that we will see later, also random memory codes. The plain number of choices to set the 0's and 1's for the whole code family is enormous and thus special algorithms have to be applied to generate random codes efficiently [J.-A. Avila-Rodriguez et al., 2007].

Finally, the technical characteristics of all the Galileo signals in E1 are summarized in Table 004.

### App C 005. Galileo E6 Band

As shown in [Galileo SIS ICD, 2010], the transmitted Galileo E6 signal consists of the following three components:

- The E6 Commercial Service (CS) data channel: this modulating signal is the modulo-two addition of the E6 CS navigation data stream  $D_{CS}(t)$  with the CS data channel code sequence  $D_{CS}^D(t)$ . This last one is already modulated by a BPSK(5) at 5.115 MHz.
- The E6 Commercial Service (CS) pilot channel: this modulating signal is the modulo-two addition of the E6 CS pilot channel code  $C_{CS}^P(t)$  with a BPSK(5) at 5.115 MHz.
- Finally, the E6 PRS channel is the modulo-two



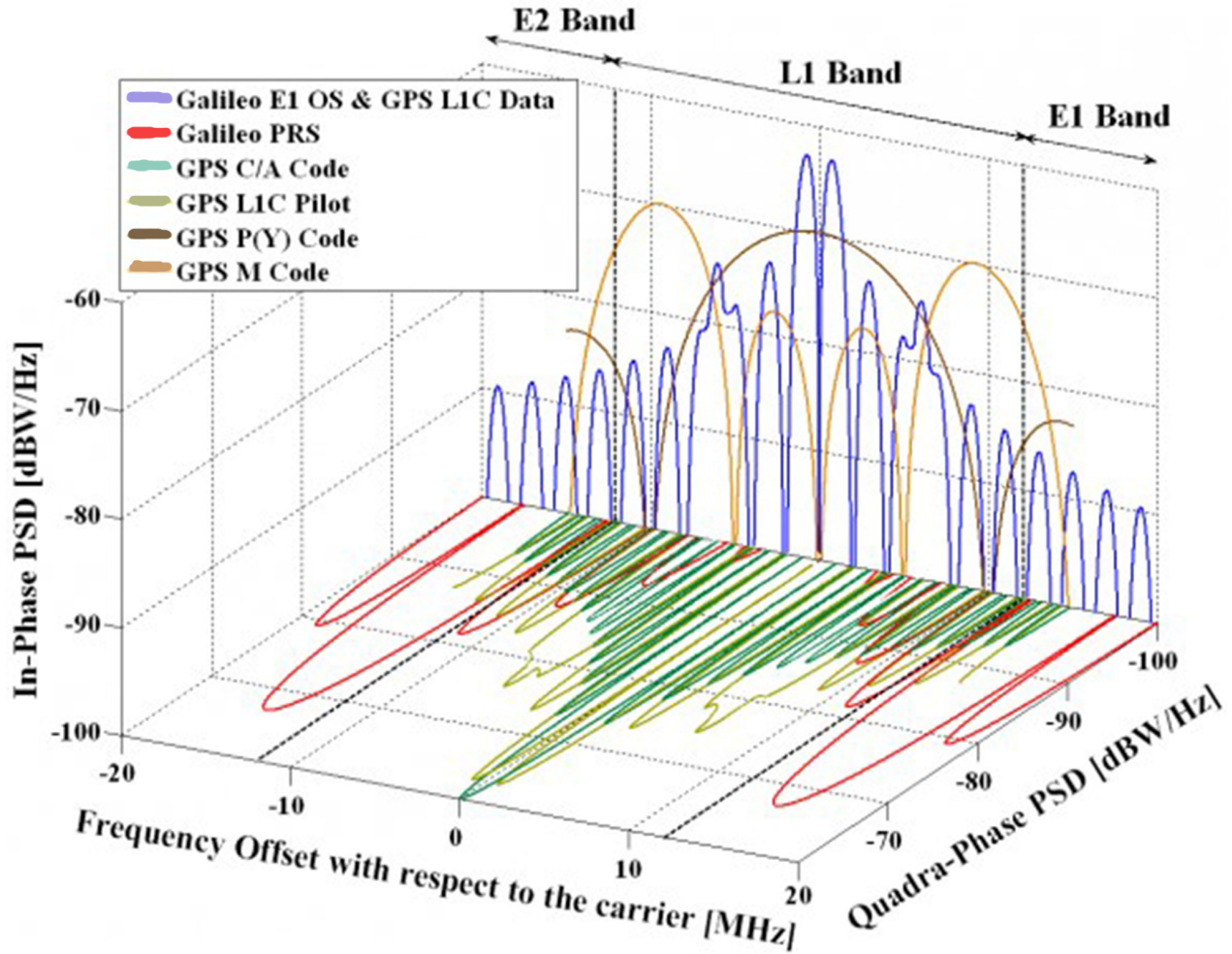

Figure 004c. Spectra of GPS and Galileo signals in L1. Image courtesy of Dr. Jose Angel Avila Rodriguez.

GNSS System	Galileo	Galileo	Galileo
Service Name	E1 OS		PRS
Center Frequency	1575.42 MHz		
Frequency Band	E1		
Access Technique	CDMA		
Spreading modulation	CBOC(6,1,1/11)		BOC <sub>cos</sub> (15,2,5)
Sub-carrier Frequency	1.023 MHz and 6.138 MHz (two sub-carriers)		15.345 MHz
Code Frequency	1.023 MHz		2.5575 MHz
Signal Component	Data	Pilot	Data
Primary PRN Code Length	4092		N/A
Code Family	Random Codes		N/A

Table 004. Galileo E1 signal technical characteristics.

GNSS System	Galileo	Galileo	Galileo
Secondary PRN Code Length	-	25	N/A
Data Rate	250 sps	-	N/A
Minimum Received Power [dBW]	-157 dBW		N/A
Elevation	10°		N/A

Table 004. Galileo E1 signal technical characteristics.

addition of the E6 PRS navigation data stream  $D_{PRS}(t)$  with the PRS channel code sequence  $C_{PRS}(t)$  at 5.115 MHz. This signal is further modulated by a sub-carrier of 10.23 MHz in cosine phasing.

This is graphically shown in Figure 005a - *Modulation Scheme for the Galileo E6 Signals* and Figure 005b - *Spectra of Galileo signals in E6*. Table 005a provides the technical characteristics of the Galileo E6 signal. The E6 Commercial Service (CS) codes are random

codes [J. Winkel, 2006]. The main idea behind is to generate a family of codes that fulfills the properties of randomness as well as possible [J.-A. Avila-Rodriguez et al., 2007]. The codes can be driven to fulfill special properties such as balance and weakened balance, where the probability of 0's and 1's must not be identical but within a well-defined range, or to realize the autocorrelation side-lobe zero (ASZ) property. This latter property guarantees that the autocorrelation values of every code correlate to zero with a delayed version of itself, shifted by one chip.

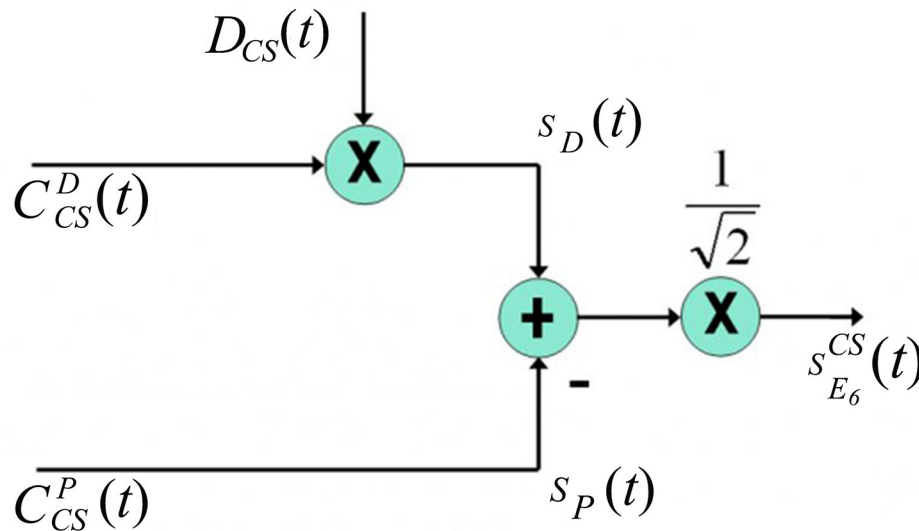

Figure 005a. Modulation scheme for Galileo E6 signals. Image courtesy of Dr. Jose Angel Avila Rodriguez.

#### App C 006. Galileo E5 Band

The different Galileo E5 signal components are generated according to the following [Galileo SIS ICD, 2010]:

- The **E5a data channel**: This channel is the modulo-two addition of the E5a navigation data stream  $D_{E5a}(t)$  with the E5a data channel PRN code sequence  $C_{E5a}^D(t)$  of chipping rate 10.23 MHz.

- The **E5a pilot channel**: This channel is the E5a pilot channel PRN code sequence  $C_{E5a}^P(t)$  of chipping rate 10.23 MHz.
- The **E5b data channel**: This channel is the modulo-two addition of the E5b navigation data stream  $D_{E5b}(t)$  with the PRS channel code sequence  $C_{PRS}(t)$  with the E5b data channel PRN code



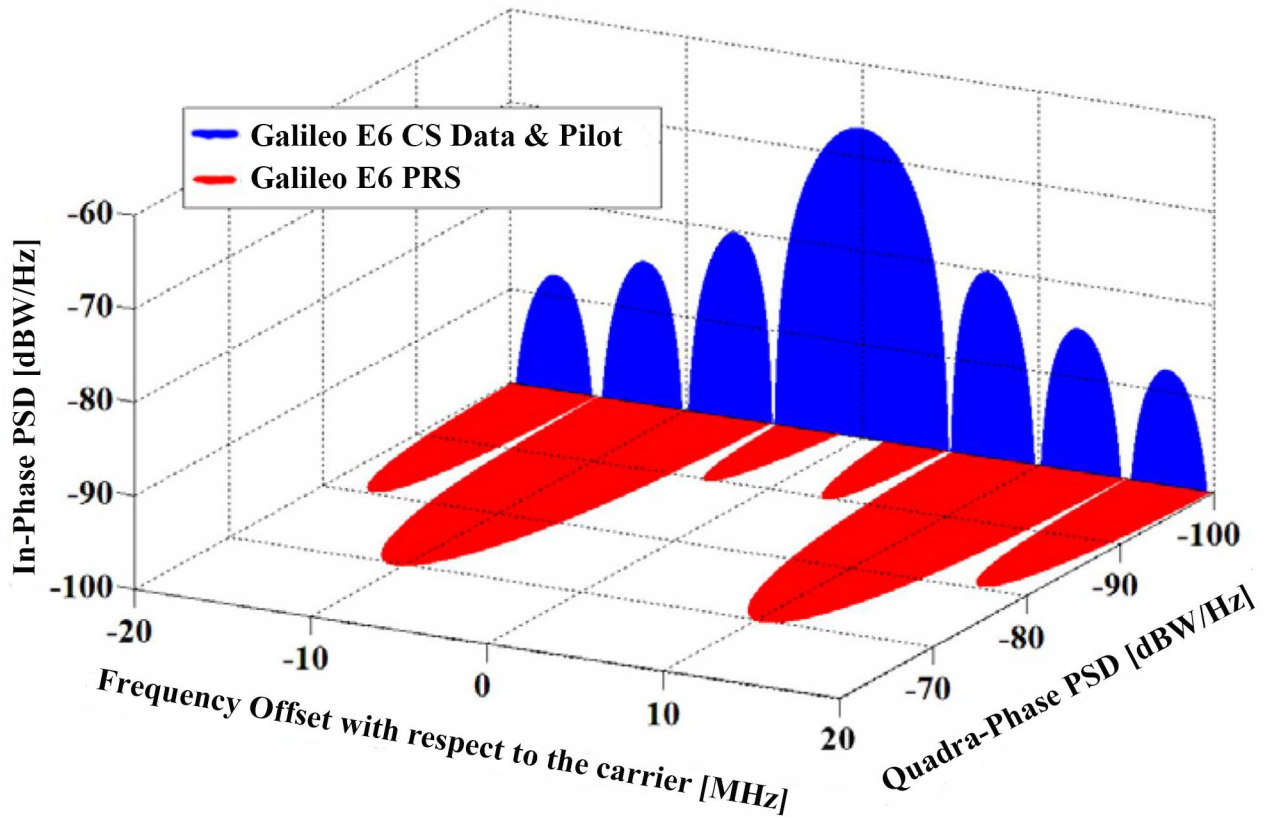

Figure 005b. Modulation scheme for Galileo E6 signals. Image courtesy of Dr. Jose Angel Avila Rodriguez.

GNSS System	Galileo	Galileo	Galileo
Service Name	E6 CS data	E6 CS pilot	E6 PRS
Center Frequency	1278.75 MHz		
Frequency Band	E6		
Access Technique	CDMA		
Spreading modulation	BPSK(5)	BPSK(5)	BOC <sub>cos</sub> (10.5)
Sub-carrier Frequency	-	-	10.23 MHz
Code Frequency	5.115 MHz		
Signal Component	Data	Pilot	Data
Primary PRN Code Length	5115	5115	N/A
Code Family	Memory codes		N/A
Secondary PRN Code Length	-	100	N/A
Data Rate	1000 sps	-	N/A
Minimum Received Power [dBW]	-155 dBW		N/A

Table 005a. Galileo E6 signal technical characteristics.

GNSS System	Galileo	Galileo	Galileo
Elevation	10°		N/A

Table 005a. Galileo E6 signal technical characteristics.

sequence  $C_{E5b}^D(t)$  of chipping rate 10.23 MHz.

- The **E5b pilot channel**: This channel is the E5b pilot channel PRN code sequence  $C_{E5b}^P(t)$  of chipping rate 10.23 MHz.

The E5 modulation receives the name of AltBOC and is a modified version of a Binary Offset Carrier (BOC) with code rate of 10.23 MHz and a sub-carrier frequency of 15.345 MHz. AltBOC(15,10) is a wideband signal that is transmitted at 1191.795 MHz. Figure 006a shows the Galileo E5 signal modulation diagram.

The power spectral density for the modified AltBOC(15,10) modulation with constant envelope is shown to adopt the form:

$$G_{AltBOC}(f) = \frac{4f_c}{\pi^2 f^2} \frac{\cos^2\left(\frac{\pi f}{f_c}\right)}{\cos^2\left(\frac{\pi f}{2f_c}\right)} \left[ \cos^2\left(\frac{\pi f}{2f_c}\right) - \cos\left(\frac{\pi f}{2f_c}\right) - 2 \cos\left(\frac{\pi f}{2f_c}\right) \cos\left(\frac{\pi f}{4f_c}\right) + 2 \right]$$

The spectrum of the E5 signal modulation is shown in Figure 006b.

As we can recognize from both figures, the AltBOC(15,10) modulation is very similar to two BPSK(10) signals shifted by 15 MHz to the left and right of the carrier frequency. Indeed, since to acquire all the main lobes of the modulation a very wide bandwidth is necessary, many receivers will operate correlating the AltBOC signal with a BPSK(10) replica.

To have a better feeling about the overlapping between GPS and Galileo in E5, Figure 006c shows all the signals de-scribed so far for this band.

The E5 primary codes can be generated with shift registers. Indeed, the outputs of two parallel registers are modulo-two added to generate the primary codes. For more details on the start values of the primary codes and the corresponding secondary codes of each satellite, refer to [Galileo SIS ICD, 2010]. Finally, some details on the technical characteristics of the E5 signal are presented in Table 006a.

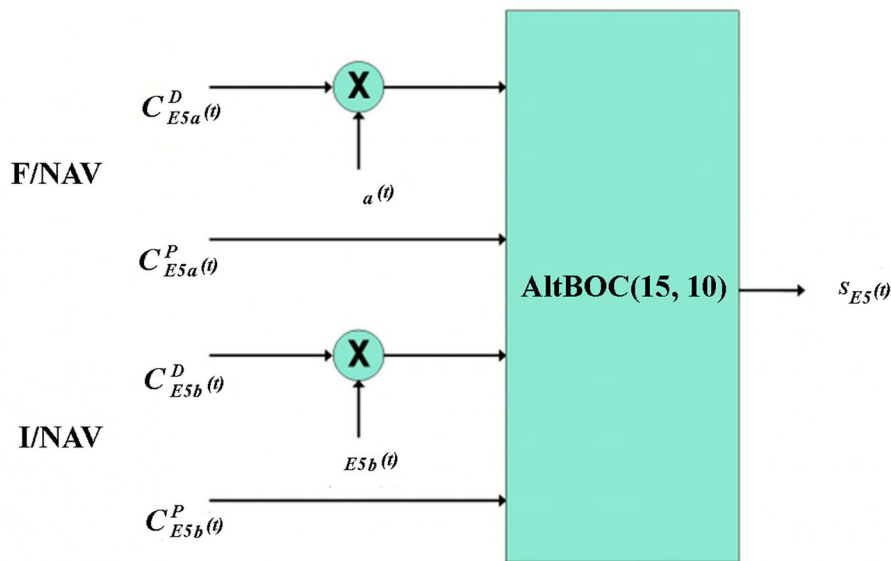

Figure 006a. Modulation scheme for Galileo E5 signals. Image courtesy of Dr. Jose Angel Avila Rodriguez.

### THE GLONASS SIGNAL PLAN

#### App C 007. GLONASS Signal Coding

GLONASS, unlike the other GNSS systems, makes use of a different DSSS technique [G.W. Hein et al., 2006c]

based on Frequency Division Multiple Access (FDMA) to transmit its ranging signals..

GLONASS uses FDMA in both the L1 and L2 sub-bands. According to this scheme, each satellite transmits

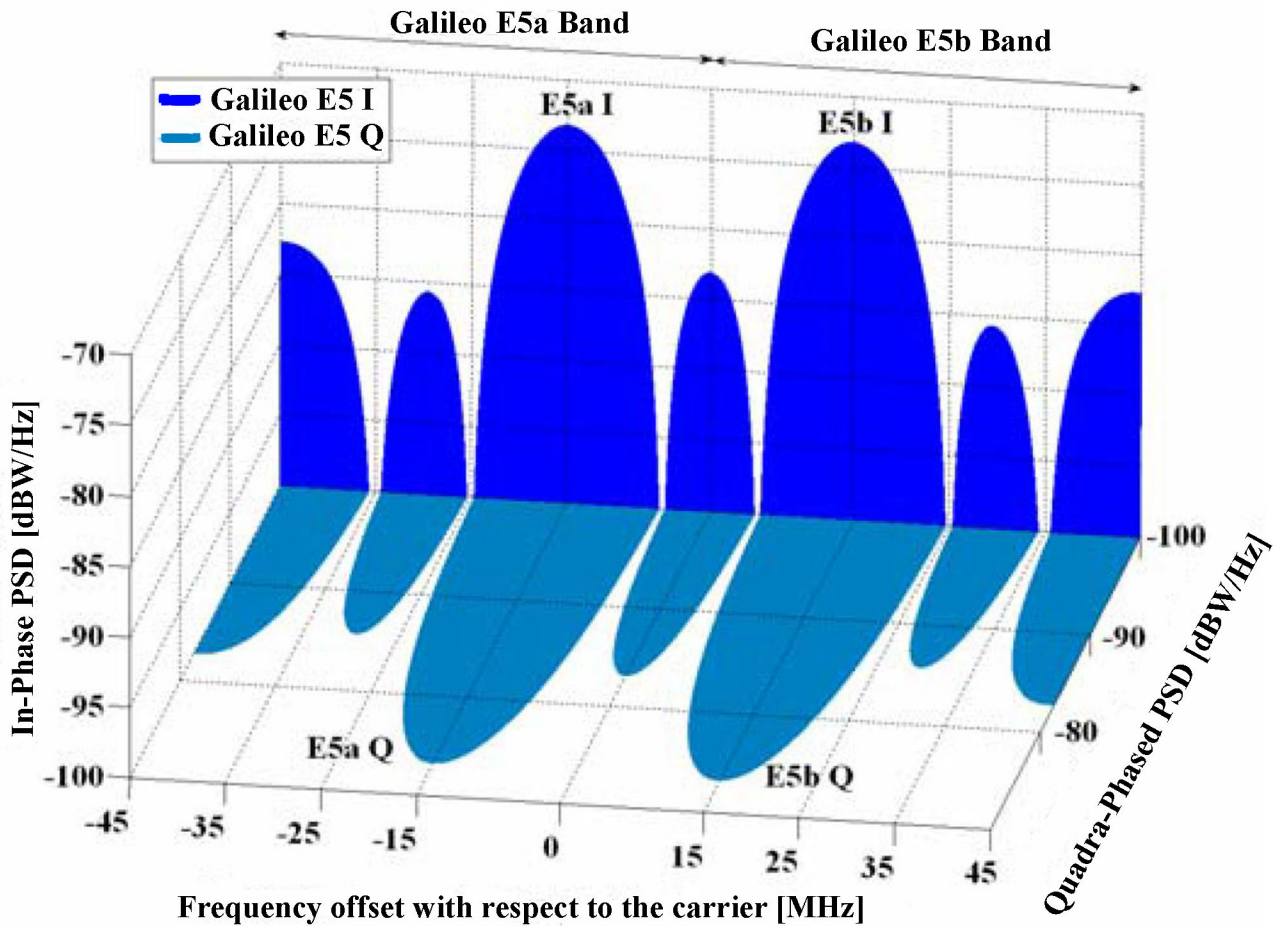

Figure 006b. Spectra of Galileo signals in E5. Image courtesy of Dr. Jose Angel Avila Rodriguez.

navigation signals on its own carrier frequency, so that two GLONASS satellites may transmit navigation signals on the same carrier frequency if they are located in antipodal slots of a single orbital plane [GLONASS ICD, 2002]. Indeed the actual constellation is taking advantage of this property since 2005 when the higher frequency channels had to be turned off to fulfill the CCIR Recommendation 769. We can clearly see this if we have a look at the satellites assigned to each of the GLONASS planes as shown in the following figure with status as of May 2008. As is clear to see, antipodal satellites are transmitting at the same frequency.

See Figure 007 for a depiction of the three GLONASS orbital planes. The red slots indicate that the satellite is in maintenance. Blue means correct operation. Moreover, two different types of signals [GLONASS ICD, 2002] are transmitted by GLONASS satellites: Standard Precision (SP) and High Precision (HP) in both the L1 and L2 bands. The GLONASS standard accuracy signal, also known as C/A Code, has a clock rate of 0.511 MHz and is designed for use by civil users worldwide while the high accuracy signal (P Code) has a clock rate of 5.11 MHz and is modulated by a special code which is only available to users authorized by

the Ministry of Defense. Since GLONASS-M, both L1 and L2 provide users with the standard accuracy code C/A. Moreover, the modernized GLONASS will also transmit FDMA signals on the L3 band and CDMA signals in L1 and L5.

The nominal values of the FDMA L1, L2 and L3 carrier frequencies are defined as:

$$\begin{aligned}
 f_{kL1} &= f_{0L1} + k\Delta f_{L1} \\
 f_{kL2} &= f_{0L2} + k\Delta f_{L2} \quad (1) \\
 f_{kL3} &= f_{0L3} + k\Delta f_{L3}
 \end{aligned}$$

where:

- $k$  represents the frequency channel,
- $f_{0L1} = 1602$  MHz for the GLONASS L1 band,
- $\Delta f_{L1} = 562.5$  kHz frequency separation between GLONASS carriers in the L1 band,
- $f_{0L2} = 1246$  MHz for the GLONASS L2 band,
- $\Delta f_{L2} = 437.5$  kHz frequency separation between

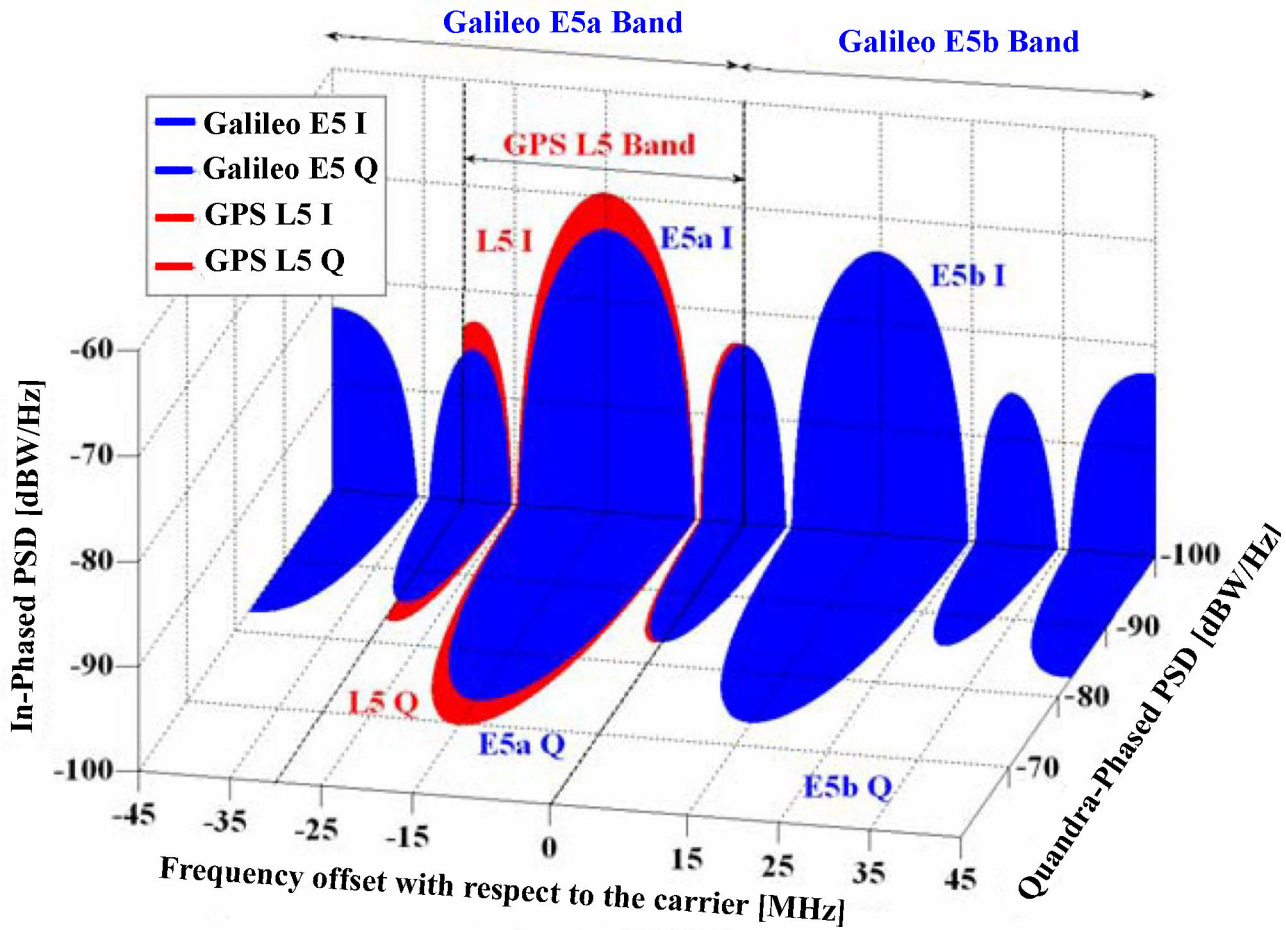

Figure 006c. Spectra of GPS and Galileo Signals in E5. Image courtesy of Dr. Jose Angel Avila Rodriguez.

GNSS System	Galileo	Galileo	Galileo	Galileo
Service Name	E5a data	E5a pilot	E5a data	E5b pilot
Center Frequency	1191.795 MHz			
Frequency Band	E5			
Access Technique	CDMA			
Spreading modulation	AltBOC(15, 10)			
Sub-carrier Frequency	15.345 MHz			
Code Frequency	10.23MHz			
Signal Component	Data	Pilot	Data	Pilot
Primary PRN Code Length	10230			
Code Family	Combination and short-cycling of M-sequences			
Secondary PRN Code Length	20	100	4	100

Table 006a. Galileo E5 signal technical characteristics.



GNSS System	Galileo	Galileo	Galileo	Galileo
Data Rate	50 sps	-	250 sps	-
Minimum Received Power [dBW]	-155 dBW		-155 dBW	
Elevation	10°		10°	

Table 006a. Galileo E5 signal technical characteristics.

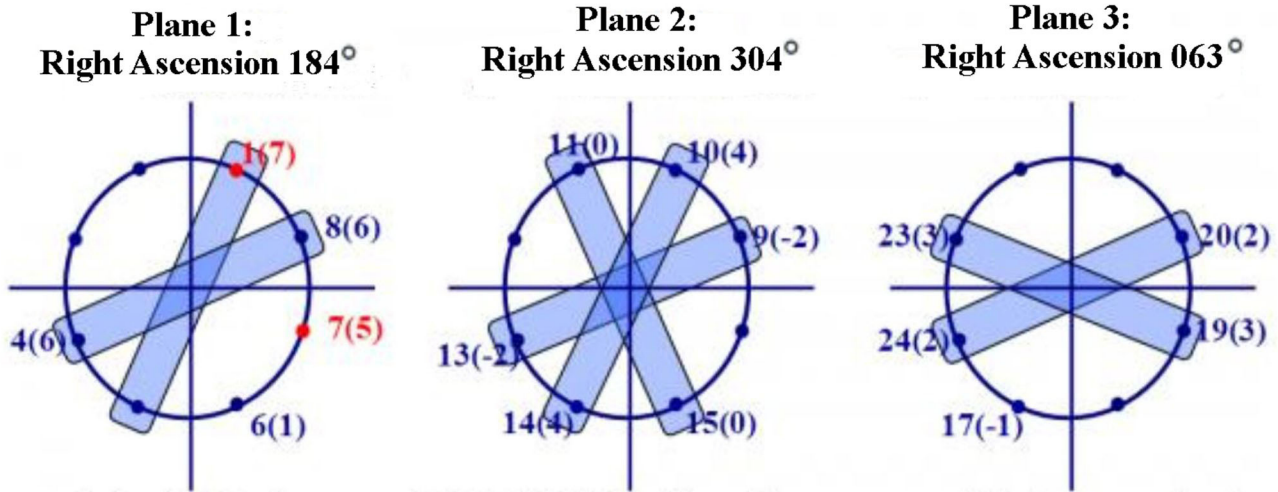

Figure 007. Antipodal assignment of GLONASS satellites. The parameter  $i(k)$  indicates that the satellite in almanac slot  $i$  transmits on frequency number  $k$ . Image courtesy of Dr. Jose Angel Avila Rodriguez.

GLONASS carriers in the L2 band,

$$f_{0L3} = 1201 \text{ MHz for the GLONASS L3 band, and}$$

$$\Delta f_{L3} = 437.5 \text{ kHz frequency separation between}$$

GLONASS carriers in the L3 band.

As we can see, the GLONASS L2 carrier reference signal is 7/9 of the L1 carrier reference and the GLONASS L3 carrier reference is 3/4 of the L1 carrier reference. Moreover, it must be noted that until 2005 the GLONASS satellites used the frequency channels  $k = 0, \dots, 12$  without any restrictions and the channel numbers  $k = 0$  and 13 for technical purposes.

Since then GLONASS is only using the frequency channels  $k = -7, \dots, +6$  and all the satellites launched beyond that year will use filters, limiting out-of-band emissions to the harmful interference limit contained in CCIR-ITU Recommendation 769 for the 1610.6 - 1613.8 MHz and 1660 - 1670 MHz Radio-Astronomy bands. It is interesting to note that although the limitation to use the higher frequency channels does only affect the L1 band, since the parameter  $k$  determines the channel in both the L1 and L2 bands, the upper frequencies of L2 corresponding to channels +7 to +13 were automatically sacrificed.

To have a clearer insight into how the spectra of the GLONASS signals look like, we study next all the bands in

detail.

### App C 008. GLONASS L1 Band and Signal Structure

The transmitted navigation signal is in both services of L1 a bipolar phase-shift key (BPSK) waveform with clock rates of 0.511 and 5.11 MHz for the standard and accuracy signals respectively. The L1 signal is modulated by the Modulo-2 addition of the pseudo random (PR) ranging code, the digital data of the navigation message and an auxiliary meander sequence. All above-mentioned frequencies are generated coherently using a single onboard time/frequency oscillator standard [GLONASS ICD, 2002]. For the case of the standard accuracy signals (C/A), the PR ranging code is a sequence with length the maximum of a shift register (m-sequence) and a period of 1 millisecond with bit rate of 511 kbps. The navigation message is sent at 50 bps and the auxiliary meander sequence at 100 Hz.

Moreover, it is important to note that the GLONASS FDMA L1 band does not exactly coincide with the GPS and Galileo L1 band. In fact, the GLONASS L1 band ranges from 1592.9525 MHz to 1610.485 MHz when only the 14 channels  $k = -7 \dots +6$  are employed. In the next figures, each of the channels was filtered to only transmit the main lobe

of the BPSK signal and the PSD was normalized to have unit power within the corresponding transmission bandwidth.

The PSDs of the GLONASS signals are shown in Figure 008a:

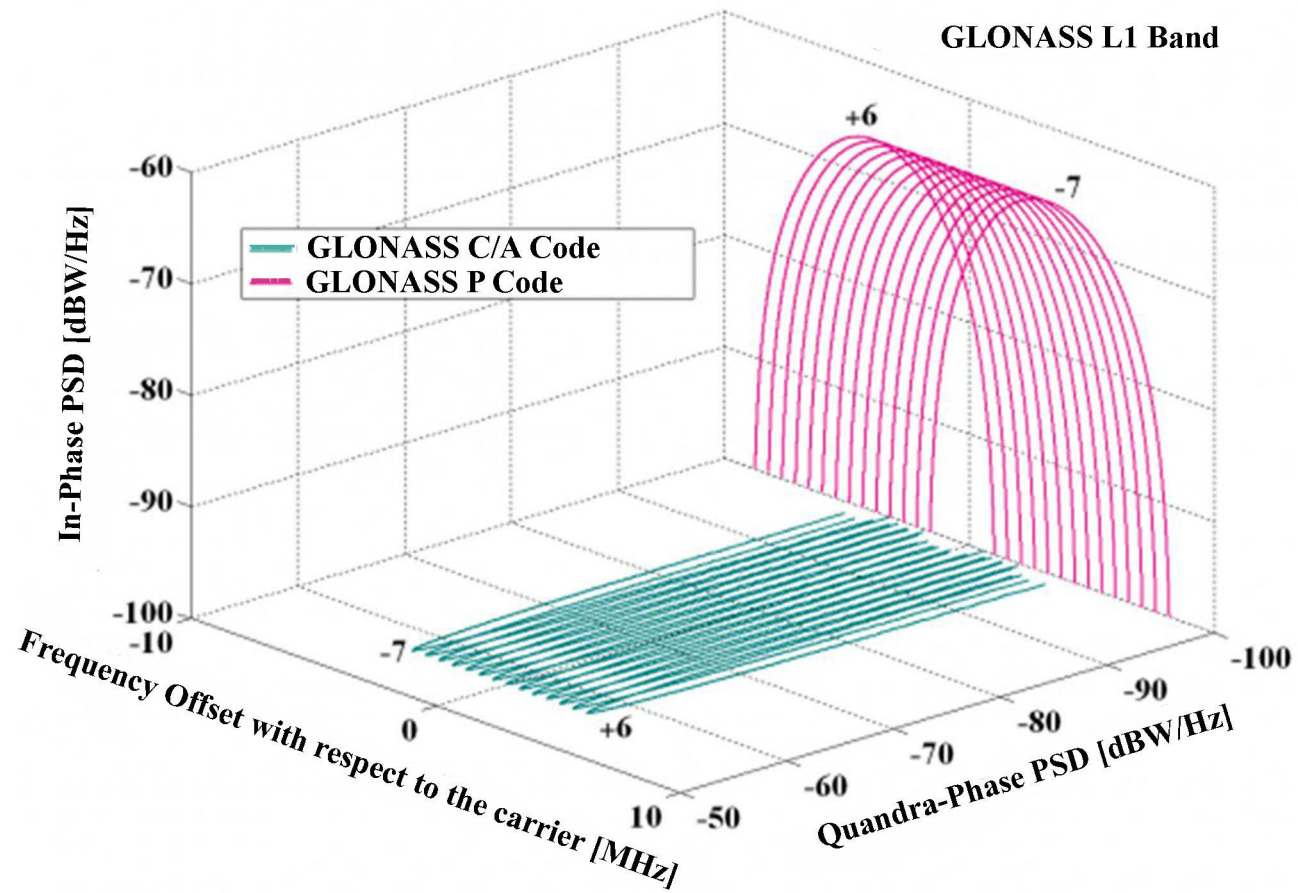

Figure 008a. Spectra of GLONASS signals in L1. Image courtesy of Dr. Jose Angel Avila Rodriguez.

Once again, in order to have a clearer picture of how overcrowded the RNSS bands are becoming as more and more countries claim their rights to have their own GNSS, Figure 008b shows GPS, Galileo and GLONASS signals in the E1/L1 band.

It is important to note that the GPS L1C pilot and data signals are shown in quadrature in Figure 008b although according to [GPS ICD-800, 2006] the final phasing is still open. To finalize some details on the technical characteristics of the GLONASS L1 signals are presented Table 008:

It is important to note that unlike for the case of GPS and Galileo, the frequencies do not have to be multiplied by the factor 1.023.

#### App C 009. GLONASS L2 Band and Signal Structure

The transmitted navigation signal is, as also in L1, a bipolar phase-shift key (BPSK) waveform with similar clock rates as in the L1 band. The L2 signal is modulated by the Modulo-2 addition of the PR ranging code and the auxiliary meander sequence. For the case of the standard accuracy

signals (C/A), the PR ranging code is a sequence of the maximum length of a shift register (M-sequence) with a period of 1 millisecond and a bit rate of 511 kbps. The navigation message is sent at 50 bps and the auxiliary meander at 100 Hz.

Figure 009a shows the spectra of the GLONASS signals in L2 and Figure 009b shows spectra of both the GLONASS and GPS signals in L2.

Details on the technical characteristics of the GLONASS L2 signals are presented in Table 009.

It is important to note again that unlike for the case of GPS and Galileo in the previous chapters, the frequencies do not have to be multiplied by the factor 1.023.

#### App C 010. References

Ávila Rodríguez, José Ángel. (2008). *On Generalized Signal Waveforms for Satellite Navigation*. University FAF, Munich. **Sections reproduced with permission.**

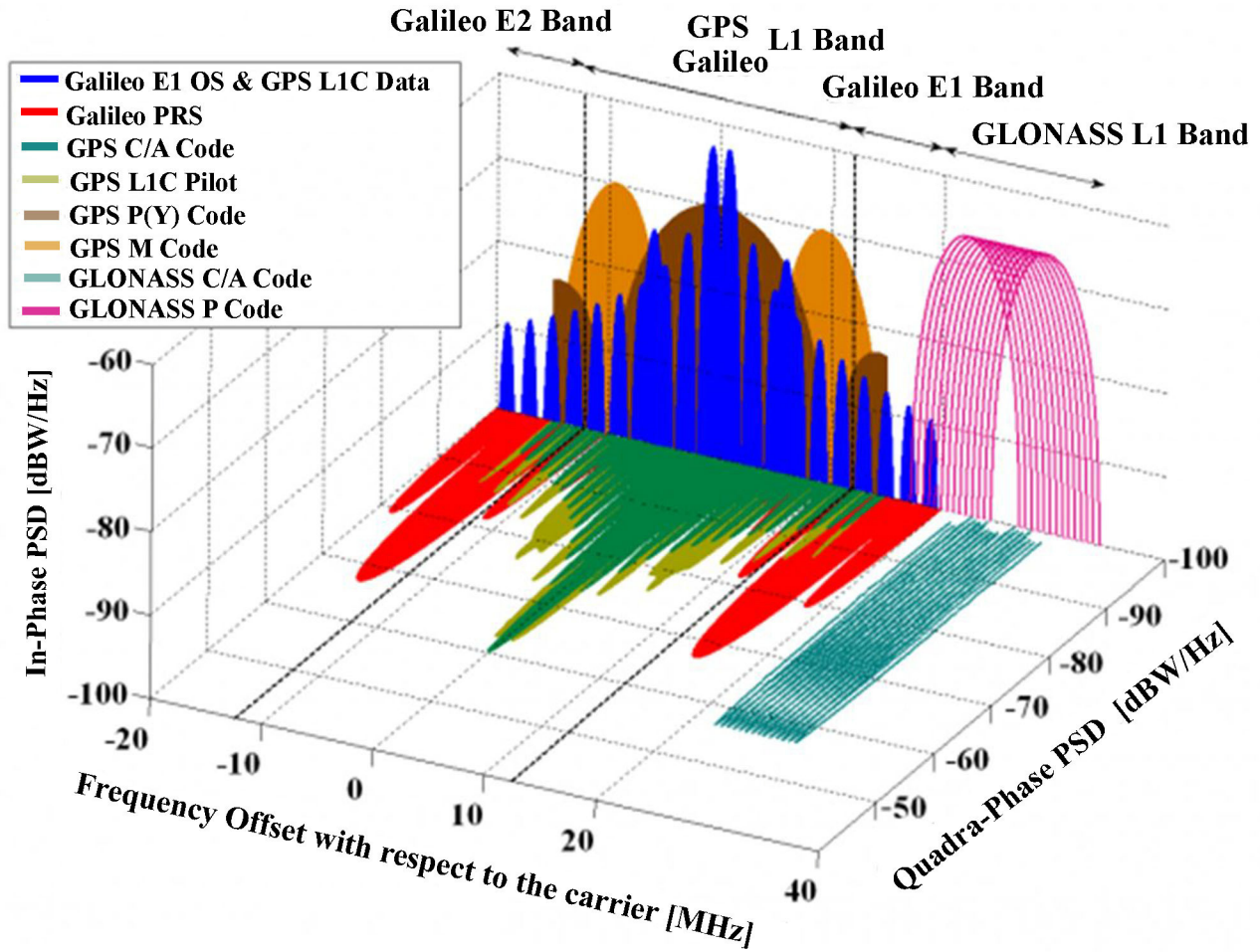

Figure 008b. Spectra of GPS, Galileo and GLONASS signals in E1/L1. Image courtesy of Dr. Jose Angel Avila Rodriguez.

GNSS System	GLONASS	GLONASS
Service Name	C/A Code	P Code
Center Frequency	(1598.0625-1605.375) MHz [+ or -] 0.511 MHz	
Frequency Band	L1	L1
Access Technique	FDMA	FDMA
Spreading modulation	BPSK(0.511)	BPSK(5.11)
Sub-carrier Frequency	-	-
Code Frequency	0.511 MHz	5.11 MHz
Signal Component	Data	Pilot
Primary PRN Code Length	511	N/A
Code Family	M-sequences	N/A
Meander sequence	100 Hz	N/A

Table 008 GLONASS L1 signal technical characteristics.

GNSS System	GLONASS	GLONASS
Data Rate	50 bps	N/A
Minimum Received Power [dBW]	-161 dBW	N/A
Elevation	5°	N/A

Table 008 GLONASS L1 signal technical characteristics.

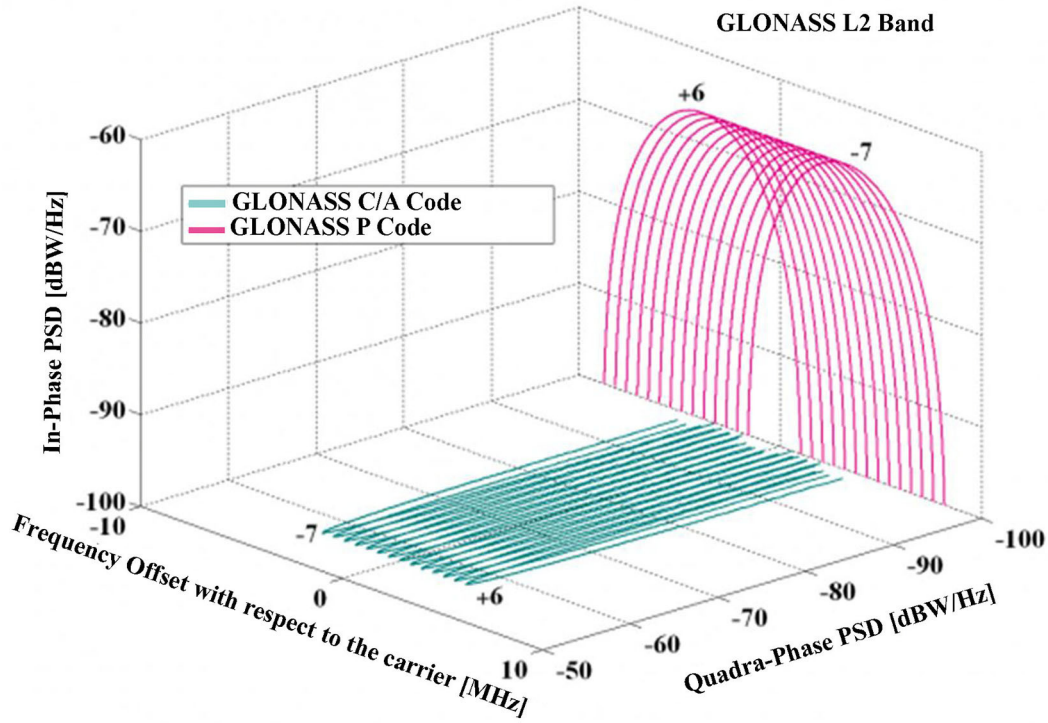

Figure 009a. Spectra of GLONASS signals in L2. Image courtesy of Dr. Jose Angel Avila Rodriguez.



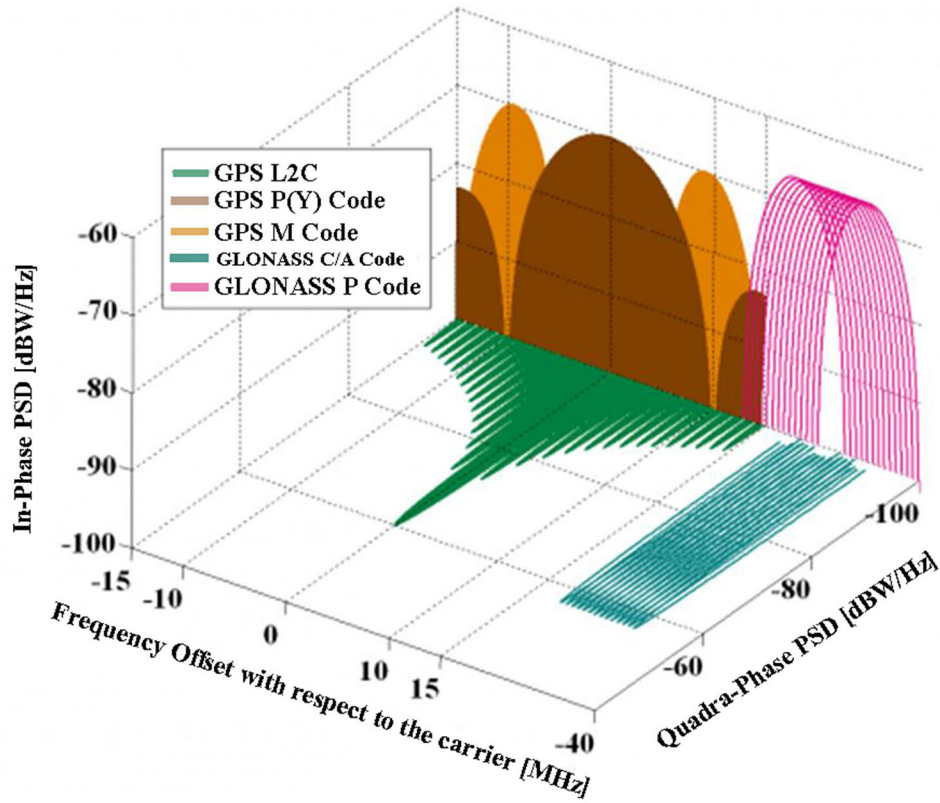

Figure 009b. Spectra of GPS and GLONASS signals in L2. Image courtesy of Dr. Jose Angel Avila Rodriguez.

GNSS System	GLONASS	GLONASS
Service Name	C/A Code	P Code
Center Frequency	(1242.9375-1248.625) MHz [+ or -] 0.511 MHz	
Frequency Band	L2	L2
Access Technique	FDMA	FDMA
Spreading modulation	BPSK(0.511)	BPSK(5.11)
Sub-carrier Frequency	-	-
Code Frequency	0.511 MHz	5.11 MHz
Signal Component	Data	Pilot
Primary PRN Code Length	511	N/A
Code Family	M-sequences	N/A
Meander sequence	100 Hz	N/A
Data Rate	50 bps	N/A
Minimum Received Power [dBW]	-167 dBW	N/A
Elevation	5°	N/A

Table 009 GLONASS L2 signal technical characteristics.